



Wetland

Technical Design Guidelines
May 2017

waterbydesign
a Healthy Land and Water initiative

VERSION	CONTRIBUTORS
WSUD Technical Design Guideline Version: June 2006	Brisbane City Council Melbourne Water WBM Oceanics Ecological Engineering
Wetland Technical Design Guideline Version: May 2017	<p>Technical content: Jason Sonneman and Shaun Leinster of DesignFlow Glenn Browning, Adrian Crocetti and Andrew O'Neill of Water by Design</p> <p>Additional input: Richard Robinson of R2A</p> <p>Sketches: Jim Gall</p> <p>Cover Photo: Paul Dubowski of BMT WBM</p>

This guideline update was funded in part by the Department of Environment and Heritage Protection.

This work is licensed under a Creative Commons Attribution-NonCommercial-NoDerivs 3.0 Unported License. Requests and enquires concerning use or reproduction should be forwarded to info@hlw.org.au.

Version 31 May 2017

Water by Design (2017). Draft Wetland Technical Design Guidelines (Version 1). Healthy Land and Water Ltd, Brisbane.

DISCLAIMER

The material contained in this publication is produced for general information only. It is not intended as professional advice on specific applications. It is the responsibility of the user to determine the suitability and appropriateness of the material contained in this publication to specific applications. No person should act or fail to act on the basis of any material contained in this publication without first obtaining specific independent professional advice. Healthy Land and Water Ltd and the participants of the Healthy Land and Water Network expressly disclaim any and all liability to any person in respect of anything done by any such person in reliance, whether in whole or in part, on this publication. The information contained in this publication does not necessarily represent the views of Healthy Land and Water Ltd or the participants of the Healthy Land and Water Network.

HEALTHY LAND AND WATER

Healthy Land and Water is a dynamic and independent not-for-profit organisation dedicated to the care of South East Queensland's unique and beautiful land, waterways and biodiversity. We share our in-depth knowledge, tools and networks to protect against the impacts of population growth and extreme weather on our natural environment. Our work also helps to protect and enhance the many social and economic benefits our natural environment provides such as recreation, tourism, agriculture and a clean drinking water supply.

Healthy Land and Water's Water by Design initiative was established in 2005 and builds the capacity of the water and urban development sectors to help successfully implement sustainable cities through better urban water management.

For further information about or to provide feedback on this guideline or other projects from Healthy Land and Water's Water by Design initiative, please email info@hlw.org.au or telephone (07) 3177 9100.

Contents

CHAPTER 1	INTRODUCTION	7
1.1	History and context of the guidelines	10
1.2	Structure of the guidelines	11
CHAPTER 2	BACKGROUND	12
2.1	What are Constructed Wetlands?	13
2.2	Design Considerations	16
2.2.1	Site suitability	16
2.2.2	Residence time and plant inundation	17
2.2.3	Water levels and plant inundation	17
2.2.4	Designing to Avoid Mosquitoes	18
2.2.5	Public Safety and Restricting Access to Open Water	19
CHAPTER 3	DESIGN PROCESS	22
3.1	Background investigations	24
3.1.1	Site analysis	24
3.1.2	Design objectives	27
3.1.3	Local authority consultation	28
3.2	Wetland Levels	29
3.2.1	Normal water level	30
3.2.2	Outlet pipe level	31
3.2.3	Constructed wetland levels relative tidal levels	31
3.2.4	Extended detention depth	31
3.2.5	Maximum water level	32
3.2.6	Regional flooding immunity	32
3.2.7	Top of embankment	33
3.2.8	Sediment basin levels	33
3.2.9	Water level indicators	33
3.3	Wetland Layout	34
3.3.1	Functional shape and location	34
3.3.2	Landscape integration	35
3.3.3	Public access	37
3.3.4	Underground services	40
3.3.5	Wetlands Constructed within flood storage	41
3.3.6	Floating Wetlands	42
3.3.7	Stormwater harvesting and reuse wetlands	43

3.4	Sediment Basin Design	44
3.4.1	Design Flows	46
3.4.2	Area	47
3.4.3	Depth and Storage Volume	49
3.4.4	Hydraulic Connection to Macrophyte Zone	50
3.4.5	Bypass/Overflow weir	54
3.4.6	Inlet energy dissipation and scour protection	55
3.4.7	High Flow Bypass Channel	56
3.5	Macrophyte Zone Design	57
3.5.1	Treatment Area	58
3.5.2	Shape	59
3.5.3	Bathymetry (or depth)	60
3.5.4	Batters	62
3.5.5	Walls	64
3.5.6	Embankments	65
3.5.7	Macrophyte Zone Outlet	66
3.5.8	Resuspension Protection	71
3.6	Maintenance access	72
3.6.1	Site access	72
3.6.2	Sediment basin access	72
3.6.3	Macrophyte zone maintenance access	75
3.6.4	Maintenance edges	76
3.6.5	Landscape integration	77
3.7	Impermeable Liner and Topsoil	78
3.7.1	Impermeable Liner	78
3.7.2	Topsoil	80
3.8	Vegetation Design	81
3.8.1	Wetland planting zones	81
3.8.2	Species selection	83
3.8.3	Species selection for resistance to water birds	92
3.8.4	Planting density	93
3.8.5	Planting set-out	94
3.8.6	Mulch for terrestrial plantings	95
3.8.7	Resilience to climatic variations	95
3.8.8	Design Calculation Summary	95
3.9	Detailed design documentation	99
3.9.1	Design checklist	99
3.9.2	Design report	99
3.9.3	Detailed design drawings	100
3.9.4	Specifications	100



CHAPTER 4	SPECIFICATION	101
4.1	How to use this section	102
4.2	Civil construction	102
4.2.1	Tolerances	102
4.2.2	Hydraulic structures	103
4.2.3	Impermeable liner	104
4.2.4	Services	104
4.2.5	Maintenance access	104
4.3	Landscape specifications	105
4.3.1	Topsoil	105
4.3.2	Mulch	106
4.3.3	Planting procedure	107
4.3.4	Plant establishment	108
4.3.5	Measures of successful plant establishment	109
CHAPTER 5	WORKED EXAMPLE	110
5.1	Constructed Wetland Worked Example	111
5.1.1	Step 1: Verify size for Treatment	112
5.1.2	Step 2: Determine Design Flows	112
5.1.3	Step 3: Design Sediment basin	113
5.1.4	Step 4: Designing the Macrophyte Zone	115
5.1.5	Step 5: Design the Macrophyte Zone Outlet	117
5.1.6	Step 6: Design High Flow Bypass Channel	120
5.1.7	Step 7: Verification Checks	120
5.1.8	Step 8: Vegetation Specification	121
5.1.9	Design Calculation Summary	122
5.2	References	124



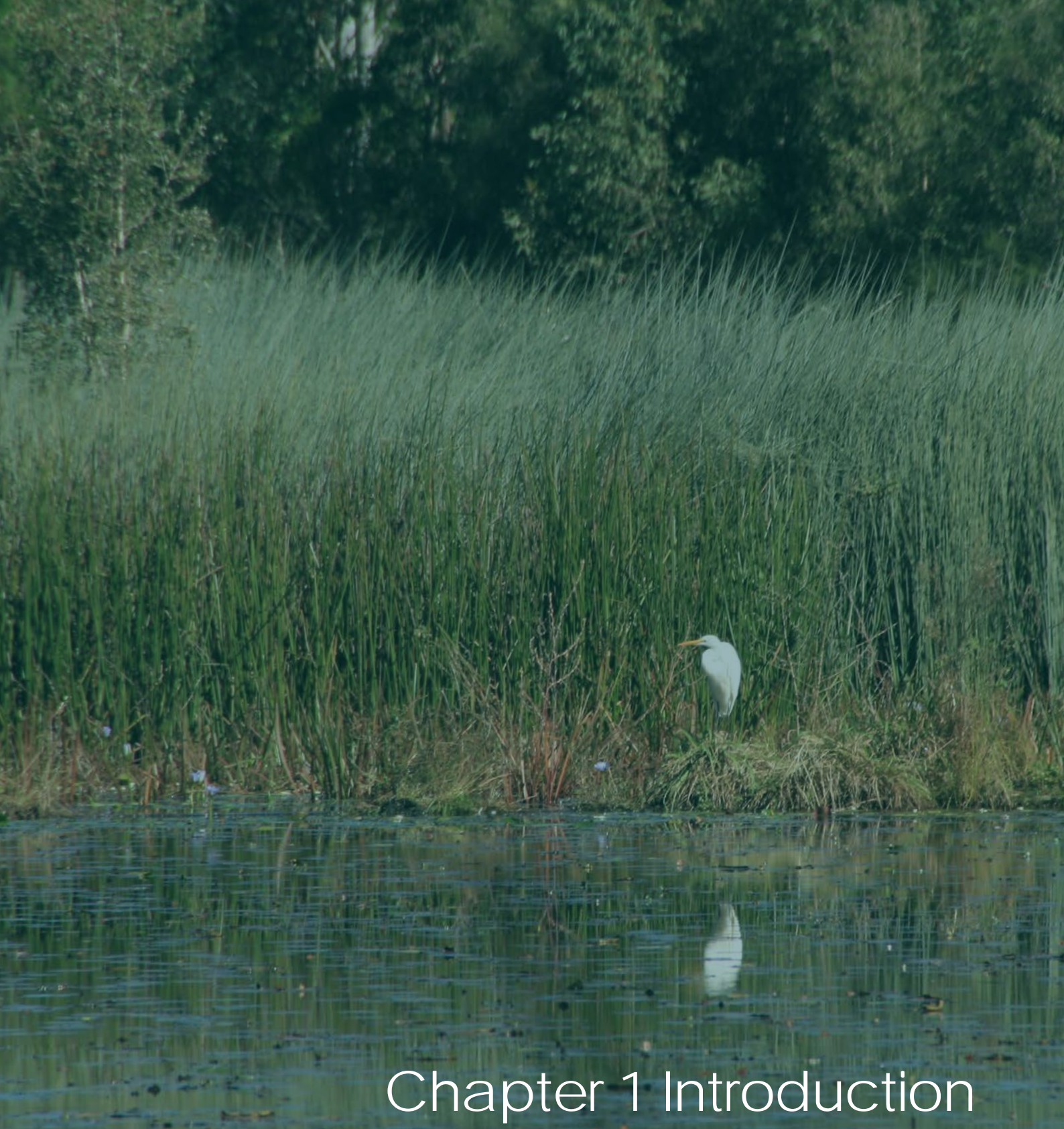

Chapter 1 Introduction

Photo: Paul Dubowski BMT WBM

Chapter 1 Introduction

Waterways and other aquatic environments are valued by the community for their social, cultural, economic and environmental benefits. As a result of urbanisation, the volume of urban runoff increases, along with contaminants such as nutrients, sediment and other pollutants which adversely impacts these valued resources. Water Sensitive Urban Design (WSUD) is a holistic approach to the planning and design of urban landscapes that seeks to minimise these negative impacts. Using this approach, designers select the treatment technology that considers the civil, landscape and ecological aspects of the site, and carefully integrate this infrastructure into the landscape to create multiple benefits for residents.

There are a variety of stormwater treatment options that are available to designers such as stormwater harvesting systems, bioretention, swales and constructed wetlands. Guidance on the planning and design of stormwater harvesting systems, bioretention, and swales in the urban context is provided in other guidelines available from <http://hlw.org.au/resources/documents>.

Although less commonly utilised than bioretention systems, constructed wetlands are chosen by designers for the amenity and habitat benefits that they provide to a local area, and their flexibility in application: on flat sites; in treating stormwater from large catchments; and with other functions such as flood or stormwater harvesting systems.

A key function of wetlands constructed in this urban context is to remove pollutants from urban stormwater.

Wetlands remove pollutants such as nutrients, heavy metals and sediment by filtering the stormwater through a densely vegetated treatment zone. As the water passes through the treatment zone, pollutants are captured via sedimentation and biological processing by both plants and biofilms. Constructed wetlands also contribute to managing hydrology by slowing the rate of discharge of stormwater to the receiving environment and reducing volume through evapotranspiration.

Careful integration and collaborative design must be adopted for constructed wetlands to ensure they provide multiple benefits. These benefits include:

- Creating or enhancing green space within the urban landscape
- Providing amenity and aesthetic values
- Providing habitat for local flora and fauna
- Educating visitors about the importance of aquatic ecosystems

When multiple benefits are achieved they assist in maximising the social, cultural, economic and environmental outcomes for the community and our waterways. To assist designers and assessors of wetland systems, Healthy Waterways has developed the Living Waterways scoring system to encourage and incentivise design solutions that embody the natural, historical and cultural elements of a site. For more information about this resource, <http://hlw.org.au/initiatives/waterbydesign/water-sensitive-urban-design-wsud>

The purpose of this guideline is to provide guidance to designers of wetlands with the purpose of both managing urban stormwater hydrology and quality, in addition to providing multiple benefits to community.

Extensive guidance is available elsewhere for identifying, mapping, and planning for the protection and rehabilitation of wetlands both in general terms and also in the non-urban context e.g.:

- Queensland Wetland Definition and Delineation Guideline (Department of Environment and Resource Management, 2010) sets out a process for government agencies, landowners, conservationists, natural resource managers and others to identify whether a feature is a wetland for decision making and planning purposes
- Queensland Wetland Buffer Planning Guideline (Queensland Department of Environment and Resource Management, 2011) produced by the Queensland Wetlands Program assists development proponents and local and state government authorities to plan and design a wetland buffer that will maintain wetland environmental values and protect wetlands from current and future threats from adjacent land uses. Available now from <http://wetlandinfo.ehp.qld.gov.au/resources/static/pdf/resources/reports/buffer-guide/wetland-bufferguideline-14-04-13.pdf>
- Wetland Rehabilitation Guidelines for the Great Barrier Reef Catchment (WetlandCare Australia, 2008) provides comprehensive guidance to farmers, community groups, NRM bodies, and local and state government authorities on planning, design, implementation, monitoring and maintenance of rehabilitation of wetlands. Available from wetlandinfo.ehp.qld.gov.au/resources/static/pdf/resources/reports/qw-rehab-guidelines-jan09.pdf.

- A series of fact sheets are available that provide guidance for land owners and managers, extension officers, and NRM bodies to design simple treatment systems in the non-urban landscape. For example the Constructed (treatment) wetlands factsheet provides simple guidance to assist in the design and implementation of constructed wetlands to reduce pollution from agricultural runoff.
- A range of other resources are available from the Queensland Wetlands Program website: <http://wetlandinfo.ehp.qld.gov.au/wetlands/management/wetland-management/>

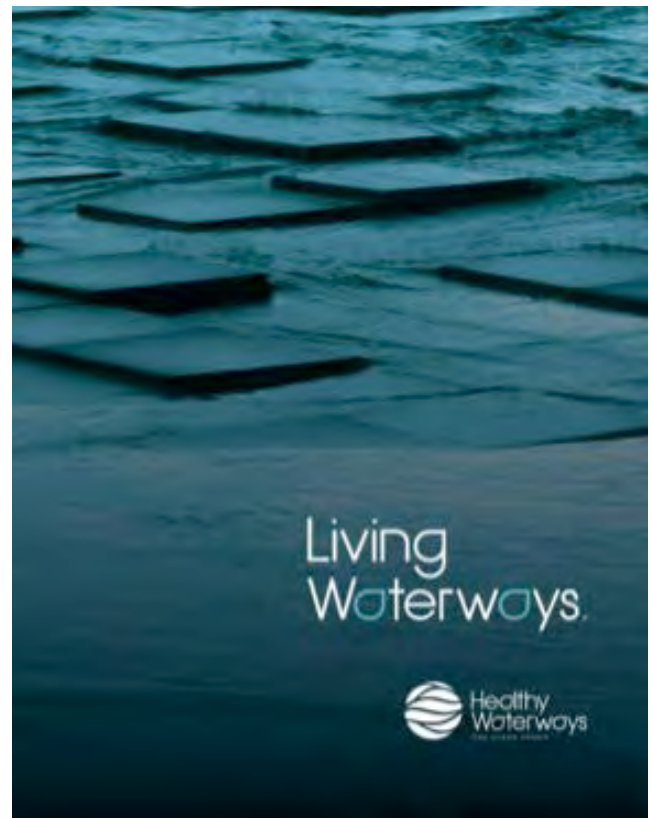

1.1 History and context of the guidelines

A comprehensive suite of tools and guidelines developed by Water by Design are available to support the planning, design and implementation of WSUD in Queensland. **Figure 1** illustrates these tools and how they can be used in the context of a typical urban development process.

The *Water Sensitive Urban Design Technical Design Guidelines for South East Queensland (Water by Design)* were first released in June 2006. They provide guidance on the design, construction, establishment and maintenance of various stormwater management systems, including constructed wetlands. Since the *Technical Design Guidelines (Water by Design)* were

first published, the design of constructed wetlands has evolved significantly.

The *Technical Design Guidelines (Water by Design)* addressed constructed wetlands in several chapters. These included:

- Chapter 1 – Introduction
- Chapter 4 – Sediment Basins
- Chapter 6 – Constructed Wetlands
- Appendix A – Plant Selection for WSUD Systems.

This guideline supersedes these chapters from the *Technical Design Guidelines*.

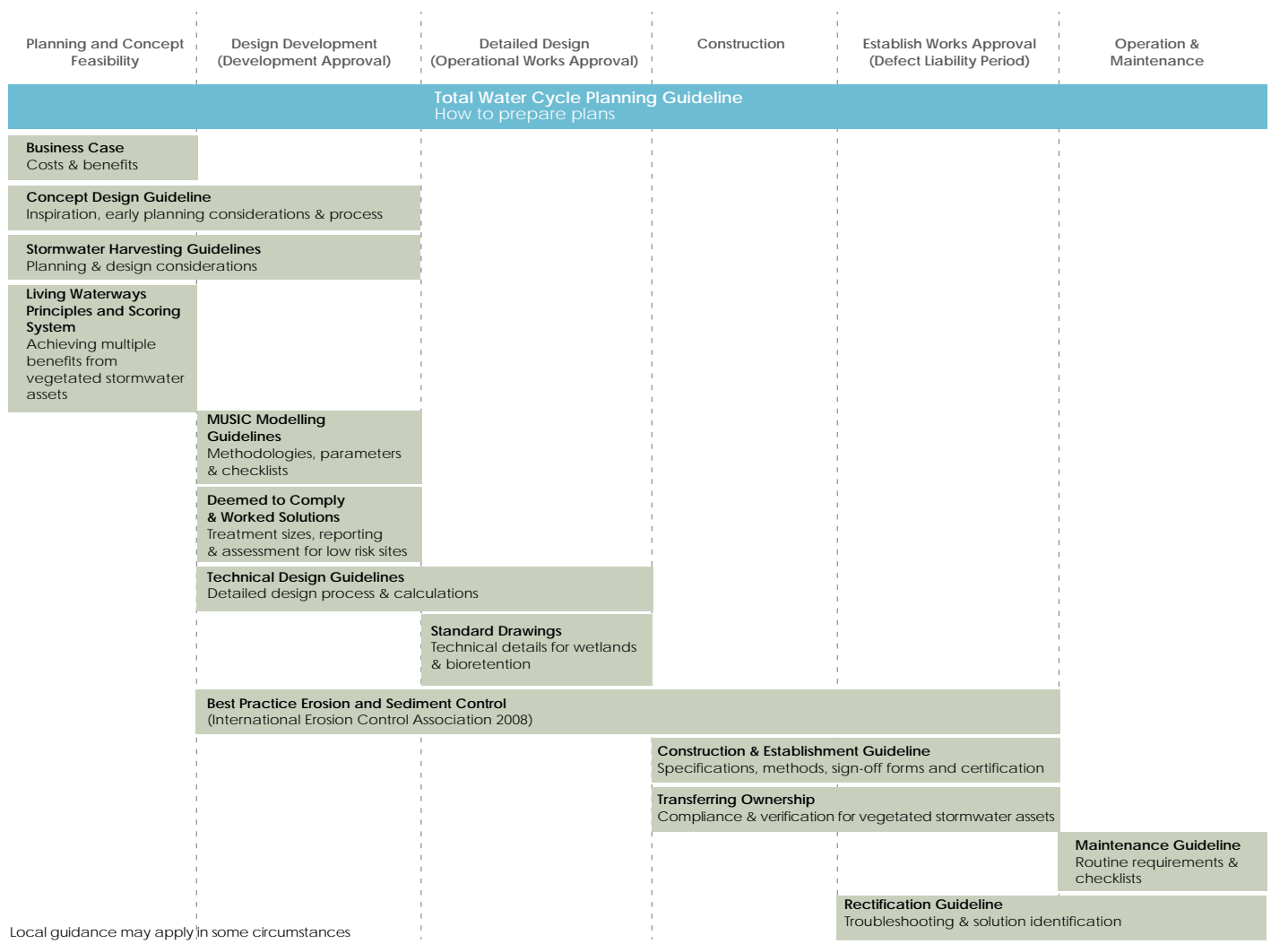

FIGURE 1 THE WSUD TIMELINE AND SUPPORTING GUIDELINES

1.2 Structure of the guidelines

Each of the five chapters of this guideline describes a particular aspect of the detailed design of constructed wetlands for urban stormwater treatment. **Table 1** outlines the content of each chapter.

TABLE 1 - STRUCTURE AND CONTENT OF THE CONSTRUCTED WETLANDS TECHNICAL DESIGN GUIDELINES

Chapter 1 – Introduction	Introduces constructed wetlands and the concept of WSUD. Provides the history, context and structure of this guideline.
Chapter 2 – Background	Provides background information critical to designing and managing constructed wetlands. It describes the key features, possible configurations of constructed wetlands as well as outlining how and in what situation they can be applied in urban settings. The concepts and nomenclature introduced are used throughout the document.
Chapter 3 – Design Process	Documents a design process that is proven to apply to the configuration of a constructed wetland, and the contexts in which they can be applied. Each component of a constructed wetland is addressed individually. Design details provided are divided into 'performance outcomes' and 'recommended approach'. The 'performance outcomes' outline the outcome to be achieved in designing each component of a constructed wetland, while the 'recommended approach' is one approach which is proven to achieve the performance outcome. This delineation is to ensure that the essential aspects of constructed wetland design are incorporated, while also encouraging innovative approaches to design.
Chapter 4 – Specification Guide	Provides standard specifications for typical constructed wetlands to assist in ensuring they are constructed correctly. The specifications can be used as an example, or where appropriate copied directly into tender packages.
Chapter 5 – Worked Example	Provides a worked example of the design of a constructed wetland. The reader is guided through the process of designing a constructed wetland in accordance with the recommended approach outlined in Chapter 3.



Chapter 2 Background

Photo: Paul Dubowski BMT WBM

2.1 What are Constructed Wetlands?

Stormwater treatment constructed wetland systems are shallow, extensively vegetated water bodies that use sedimentation, fine filtration and biological uptake processes to remove pollutants and are one of a number of different treatment options for removing contaminants from urban stormwater. Water levels rise during rainfall events and outlets are configured to slowly release flows, typically over two to three days, back to the normal

water level. In addition to treating stormwater, constructed wetlands can also provide habitat, passive recreation, improved landscape amenity and temporary storage of treated water for reuse schemes.

Figure 2 shows the key elements of constructed wetland systems.

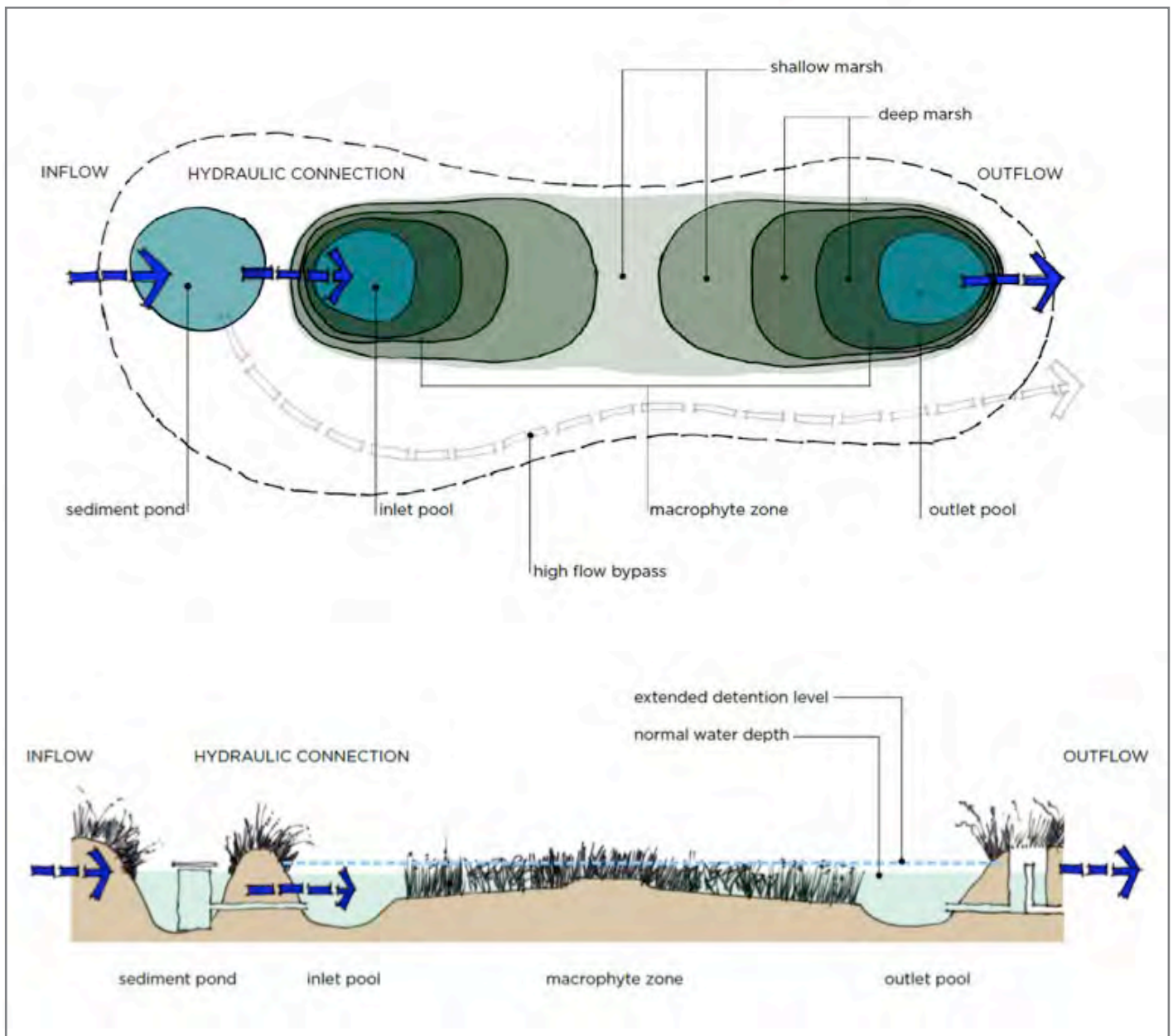

FIGURE 2 Schematic Layout of a Constructed Wetland System

TABLE 2 - CONSTRUCTED WETLAND DESIGN REQUIREMENTS

DESIGN ELEMENT	FUNCTION	DESIGN REQUIREMENT
Sediment Basin	Captures and stores coarse sediments protecting the downstream macrophyte zone	Sediment basin should be sized to capture 90% of 125µm particles from the 1 year ARI flow event. Typically 1.5 to 2 m deep. Accessible for maintenance and sediment removal.
Macrophyte zone area	Predominantly wet marsh zone (80% +) which may include open water zones. Physical, chemical and biological processes intercept and remove fine sediment and associated particulate nutrients and heavy metals, soluble nutrients, and pathogens from stormwater.	Macrophyte area defined by performance assessment (i.e. MUSIC modelling).
Macrophyte zone shape	Wetlands function better when contact of stormwater with plants is high.	Minimum length to width ratio of 5(L):1(W).
Macrophyte Zone depths	Must support plant coverage of greater than 80% of the surface area of the macrophyte zone. Bathymetry should promote a sequence of shallow marsh, deep marsh and small open water zones.	Depth is less than or equal to 0.4 m for a minimum 80% of the surface area with a mix of depths preferred. Base to slope at 1 in 150 (i.e. 0.67%) grade or greater (no flat benches)
Extended detention	During storm events, stormwater fills the extended detention storage (i.e. above the plants) and then drains following cessation of rainfall. The extended detention is a balance between the amount of stormwater that can be captured and the depth of inundation that wetland plants can tolerate.	Extended detention depth generally 0.3 to 0.5 m (maximum)
Deep Pool	Provides for hydraulic pipe connection into and out of the macrophyte zone as well as refuge for mosquito predators during the dry season.	Depth typically 1.2 – 1.5 m (maximum)
Macrophyte Zone Outlet	Controls the flow through the wetland to ensure that water receives treatment for a sufficient time period.	Macrophyte zone residence/ detention time is more than 48 hours 90% of the time
Macrophyte Zone normal water level	Suitably high enough to ensure free drainage of the wetland to the receiving drainage system or waterway and allow lowering the normal water level during vegetation establishment and maintenance.	Normal water level of the wetland should generally be >0.5 m above the invert or ponded water level within the receiving drainage system or waterway to allow lowering of water level. Reduced normal water levels can be adopted in accordance with this guideline.

DESIGN ELEMENT	FUNCTION	DESIGN REQUIREMENT
Bunds or Embankments	The bunds and embankments hold stormwater in the constructed wetland. The bund/embankment level needs to be suitably high enough to ensure the required design storm flows can enter the overflow pit or overflow weir.	Bund/embankment level is generally a minimum of 0.5 m above the top of extended detention to allow for head above overflow outlet and freeboard. For small-scale applications such as car parks, streets and allotments the level may be reduced provided there is a suitable flow path for stormwater to drain from the site.
Batters	Integrate local ground to the wetland and both limit access and allow safe egress	Shallow batter slopes above and directly below normal water level. For more information, refer to Section 3.5.4
Liner	Macrophyte zone base must be of suitable material to retain water to sustain vegetation and provide habitat and amenity values.	Hydraulic conductivity less than 10 ⁻⁹ m/s. Prefer compacted clay liner of 300m thickness. If in-situ soils are unsuitable for water retention, clay liner will need to be imported. Synthetic liners may be adopted subject to approval by local authority.
Topsoil	Suitable topsoil is crucial to successful macrophyte establishment and long-term wetland performance.	Minimum depth 200mm. Wetland design levels should be inclusive of topsoil. Topsoil must meet AS 4419.
Vegetation	Vegetation filters stormwater and takes up pollutants	Vegetation to be planted in bands to promote distributed flow
Maintenance access	A dedicated access to the constructed wetland which allows for easy and cost effective maintenance.	Access must be provided to sediment basin, around perimeter of wetland and to all hydraulic structures to allow for maintenance in accordance with this guideline.
High flow bypass	Conveys overflow flows away from the macrophyte zone providing protection to plants and preventing bed scour and resuspension of pollutants as well as disturbance of biofilms.	Designed to convey the maximum overflow from the sediment basin (typically >1 year ARI).

2.2 Design Considerations

The operation of constructed wetlands involves the interaction between stormwater runoff and vegetation. Successful design and construction of wetlands requires the careful design of shape, depths and hydraulic structures along with the selection of correct plants to ensure they provide a water quality function and integrate with the surrounding landscape. The following sections provide an overview of the key design issues that must be considered when conceptualising and designing constructed wetlands.

2.2.1 SITE SUITABILITY

Well designed constructed wetlands for stormwater treatment are valuable assets to the local community; therefore, it is important that their size and location are appropriate for function, aesthetics, constructability, and maintenance requirements. **Table 3** outline the typical situations when wetland are suitable and **Table 4** outlines situation when wetlands are not suitable.

TABLE 3 - WHEN TO USE CONSTRUCTED WETLANDS

SITUATION	WHY WETLAND IS SUITABLE
For managing litter, sediment, nutrients, metals and hydrocarbons transported by stormwater	Constructed wetlands are effective at removing anthropogenic and organic litter, coarse/fine sediment, phosphorus, nitrogen, metals and hydrocarbons from stormwater. Where the volumes of litter or coarse sediment loads are high, further pre-treatment (i.e. gross pollutant trap) may be required.
For managing stormwater flows	Constructed wetlands systems can be used to manage urban hydrology, particularly frequent stormwater flows. They can also be combined with flood storage for large events (i.e. in the base of flood storage basin).
For urban or civic landscapes, residential parkland and riparian and bushland landscapes	Constructed wetlands have a flexible design and their vegetated finish allows them to be easily incorporated into a range of landscapes, from hard edge civic spaces to more natural residential parkland, bushland, or riparian settings.
For large catchments	Constructed wetland systems can manage runoff from large catchments if design solutions specifically developed for large systems are used
For catchments with baseflows	Constructed wetlands can cope with persistent baseflows better than bioretention basins
On flat topography	Due to minimal vertical fall requirements, constructed wetlands have the potential to be used on flat topography. Wetlands can be designed in situations where there is as little as 0.5m difference between inlet and outlet level.
For stormwater harvesting	Constructed wetlands can treat stormwater to a level suitable for some forms of re-use and can be used as an effective collection point or temporary storage for treated stormwater. It is important to account for any potential water losses when estimating yields for stormwater harvesting systems.

TABLE 4 - WHEN NOT TO USE CONSTRUCTED WETLANDS

SITUATION	WHY CONSTRUCTED WETLANDS ARE NOT SUITABLE
For sites with tidal influence	Saline water compromises the biological function of freshwater constructed wetlands. Marine wetlands can be used to treatment stormwater, however, these are not covered in this guideline.
For sites with high velocities	High-flow velocities are likely to scour wetland systems
For sites subject to toxic runoff	When the system is likely to be exposed to toxic substances (e.g. herbicides, solvents or industrial contaminants), biological function will be compromised. Structural separation should be used to exclude contaminants from the stormwater system.
When the system cannot be easily accessed for maintenance	Constructed wetlands require periodic maintenance to ensure optimal function. As such, it is essential that easy access for maintenance is available.
Where implementation of a wetland does not fit with the surrounding landscape context	Wetland footprint may disturb high value natural environment. For example change to hydrology could impact on natural wetlands

2.2.2 RESIDENCE TIME AND PLANT INUNDATION

Residence time is defined as the time taken for each 'parcel' of water entering the wetland to travel through the macrophyte zone assuming 'plug' flow conditions. The residence time varies depending on inflow/outlet rates and water level in the wetland. The term is used throughout this guideline to provide a point of reference in modelling and determining the design criteria for riser outlet structures.

Notional detention time, used in Model for Urban Stormwater Improvement Conceptualisation (MUSIC) (eWater), is defined as the nominated time of detention of stormwater in the wetland at the top of extended detention assuming constant inflow and outflow (i.e. residence time under one scenario which the wetland is full and there is constant inflow and outflow).

The residence time for constructed wetlands in Queensland should be 48 hours or more 90% of the time. This will ensure wetland treatment performance is accurately modelled in MUSIC and the health of wetlands plants is ensured. Where lower residence times are adopted the reliability of the MUSIC in

predicting wetland performance is questionable.

In highly constrained sites, the size of the wetland may become small in relation to the catchment (i.e. <2% of catchment). In these situations there is risk that water levels will remain above normal water level for long periods of time due to increased inflows, resulting in potential drowning of the plants. In these situations, water level analysis must be undertaken by an experienced hydrologist and wetland ecologist to adjust the wetland bathymetry, outlet and planting design to suit the water level conditions in the wetland.

2.2.3 WATER LEVELS AND PLANT INUNDATION

Emergent water plants are sensitive to inundation depth, frequency and duration (especially during plant establishment). Whilst water plants possess a range of biochemical, molecular and morphological adaptations to inundation; it is a major constraint on plant function, interfering with photosynthesis, flowering and pollination.

The persistence of high water levels within a wetland can therefore result in detrimental impacts on plant health, and lead to a reduction of emergent water plant cover within the wetland.

Understanding the wetland water levels is therefore important during the design phase. The adoption of a 48 hr notional detention time generally provides hydrologic conditions that are suitable for water plant survival. In certain situations, it may be possible for the wetland water levels to persist at an elevated level at or above the normal water level, even with the adoption of a 48 hr notional detention time. This may occur where the wetland:

- is undersized compared to the contributing catchment area
- has more than 0.5 m extended detention depth
- has permanent base flows

In situations where elevated water levels are likely (e.g. when one of above scenarios applies), inundation frequency and high spells analyses should be undertaken to determine the potential impacts of elevated water levels on plant health. As a general guide, it is recommended that effective water depth (permanent pool depth plus EDD) must not exceed half of the average plant height for more than 20% of the time (refer to Section 3.8 for further information).

2.2.4 DESIGNING TO AVOID MOSQUITOES

Constructed wetlands provide a range of aquatic habitats suitable for mosquito breeding and harbourage including shallow water areas, dense vegetation and moist sediments. The design of constructed wetlands, particularly in coastal areas, needs to consider existing mosquito populations as well as future potential mosquito risks.

A formal audit and risk assessment of mosquito populations associated with a proposed development site can often inform the wetland design. In some cases, local council mosquito management requirements may also need to be considered.

There are a number of wetland design elements that can be considered to reduce the risk of mosquitoes inhabiting constructed wetlands:

- Locating wetlands beyond the flight range of the important local mosquito species (requires mosquito risk assessment to identify local mosquito populations)
- Providing access for mosquito predators, such as fish and predatory insects, to all parts of the water body (i.e. avoid isolated areas of water).
- Providing permanent water areas (for long dry periods or when water levels are artificially lowered) so that mosquito predators can survive in the wetland.
- Utilising open water areas (up to 2 m depth) to promote wave action which discourages mosquito egg laying and disrupts the ability of mosquito larvae to breathe.
- Providing a free draining bathymetry such that regular wetting and drying is achieved and water draws down evenly so isolated pools are avoided.
- Providing gross pollutant control at the inlet such that human derived litter does not accumulate and provide breeding habitat. It is therefore important to implement a regular maintenance regime to remove this litter.
- Providing access to all wetland areas for mosquito monitoring and management.
- Providing a vegetation barrier adjacent to the wetland to interrupt mosquito flight paths and provide an effective barrier treatment (using residual insecticides). Refer to local council for guidance on barrier treatments.
- Ensuring that the high flow bypass and overflow channels are free draining (don't hold water after storm events).
- Monitoring for mosquitoes prior to and after construction of wetland should be considered to provide information to community and to adaptively improve future design

Mosquitoes and wetland vegetation

Many mosquito species rely upon the presence of aquatic vegetation (both emergent and floating) for survival. Generally, wetlands with minimal or no vegetation do not support large mosquito populations.

A number of mosquito guidelines recommend that constructed wetlands should not have emergent vegetation to minimise the presence of mosquitos (REFS). It should be noted that this advice is contrary to the recommendations provided in these guidelines and contrary to the functional performance of treatment wetlands.

It is clearly not practical to design treatment wetlands without vegetation cover. If a mosquito risk is present, wetland designers should consider using emergent water plant species that are adapted to growing in deeper water. Robust species that develop an 'open' canopy and do not produce large amounts of organic material (such as *Typha* spp. and *Phragmites australis*) should be used.

2.2.5 PUBLIC SAFETY AND RESTRICTING ACCESS TO OPEN WATER

Urban waterways, stormwater drainage and stormwater treatment systems can represent a significant safety risk, especially during flooding. Under the Queensland *Work Health and Safety Act 2011* (WHS 2011), *Work Health and Safety Regulation 2011*, and the *Safe design of structures Code of Practice 2013*, designers of these structures or systems have duty of care obligations for safe design. "Safe design means the integration of control measures to eliminate or, if not reasonably practicable, minimise risks to health and safety throughout the life of the structure being designed."

The *Safe design of structures Code of Practice 2013* (the Code) is a practical guide to achieving the standards of health, safety, and welfare required under the WHS 2011 and the WHS Regulation 2011. It may be used by the Court in determining what is known about a hazard, risk, or control, and in determining what is reasonably practicable.

The Code specifies the key elements of safe design, including the use of a risk assessment and risk management approach and consideration of structure or system lifecycle. It also provides a systems' approach for integrating design and risk management, and the provisions should be followed when designing constructed wetlands.

PERFORMANCE OUTCOME

Constructed wetland design makes provision for public safety through eliminating, mitigating or minimising risk so far as reasonably practicable, through:

- Ensuring safe egress from the sediment basin or wetland through batter design
- Adopting control measures such as fencing or dense planting and around identified hazards.
- Adopt warning measures such as signage where appropriate.

¹ Safe design of structures Code of Practice 2013. Workplace Health and Safety Queensland. Queensland Government. p6.

RECOMMENDED APPROACH

Attention is drawn to the *Queensland Urban Drainage Manual (DEWS 2013)* (particularly Section 12) for guidance in specific risk assessment and the implementation of control measures for these types of structures. It is recommended that the risk assessment match hazards to vulnerable groups that may be exposed to those hazards. For example, a water hazard for a toddler may not be a hazard for a competent adult, and the resulting controls may be different.

As part of the risk assessment, safety hazards may include:

- Deep water
- Fast flowing water
- Falls from a height

Hazards, likelihood of consequences, and resulting risk are required to be evaluated for the entire lifespan of the project (e.g. design, construction, operation, maintenance).

Designers should evaluate all available practicable precautions or controls. These should be designed in a hierarchy:

1. Avoid – hydraulic design should minimise areas of deep and / or fast flowing water
2. Minimise - There is much that designers can do to minimize risk. This includes the design of edge and batter profiles (refer Section 3.5.4) that facilitate public egress from areas with standing water
3. Mitigate – incorporation of appropriate visual and other sensory signals to make pedestrians, cyclists, parents and children aware that there is water nearby, and provide visual and / or physical barriers such as dense vegetation
Mitigation fencing or barriers – where water depths and edge profile requires physical barriers to public access.

Each designer then needs to assess on balance which precautions can be justified, based on the balance of the significance of the risk vs the effort required to reduce it.

As a general principle the designer should aim to minimise the use of exclusion fencing by selecting design elements with lower risk factors (e.g. flatter batters and / or dense edge planting).

Where determined necessary through risk analysis, fences or vegetation barriers to restrict access should be incorporated into wetland areas, particularly on top of concrete or stone walls where:

- there is a risk of serious injury in the event of a fall (over 0.5 m high and too steep to comfortably walk up/ down or the lower surface or has sharp or jagged edges)
- there is a high pedestrian or vehicular exposure (on footpaths, near bikeways, near playing/ sporting fields, near swings and playgrounds etc)
- where water ponds to a depth of greater than 300 mm on a constructed surface of concrete or stone.

Reference can be made to *Batter Slope Treatment and Fencing Guidelines for Constructed Wetlands and Flood storages* (Lake Macquarie City Council, 2009) for guidance on choosing fences or barriers appropriate to your scenario. Note that these scores are not evidence or probability based. Therefore, the outcomes recommended by these tables are not prescriptive and should be used as a guide only. Note also that every design is different, as such designers need to adapt designs according to their own project's particulars.

Dense littoral planting around the wetland and particularly around the deep open water pools and the sediment basin (with the exception of any maintenance access points), will deter public access to the open water and create a barrier to improve public safety. Careful selection of plant species (e.g. tall, dense or 'spiky' species) and planting layouts can improve safety as well as preventing damage to the vegetation by trampling.



Figure 3 Example of temporary fencing during plant establishment

Photo by Shaun Leinster

Dense vegetation (hedge) at least 2.8 m wide and 1.2 m high (minimum) may be suitable if vandalism is not a demonstrated concern (this may be shown during the initial 12 month maintenance period). A temporary fence (e.g. 1.2 m high silt fence or paraweb fence **Figure 3**) will be required until the vegetation has established and becomes a deterrent to pedestrians/ cyclists.

Where appropriate, depth markers may be placed within deep open water areas and should be clearly

visible from the side of the wetland or sediment basin. Safety signage may also be appropriate.

Safety hazards and control measures should continue to be monitored, reviewed and reported throughout the project lifecycle with an appropriate QA system. This will help to provide opportunities for evaluation and continuous improvement.

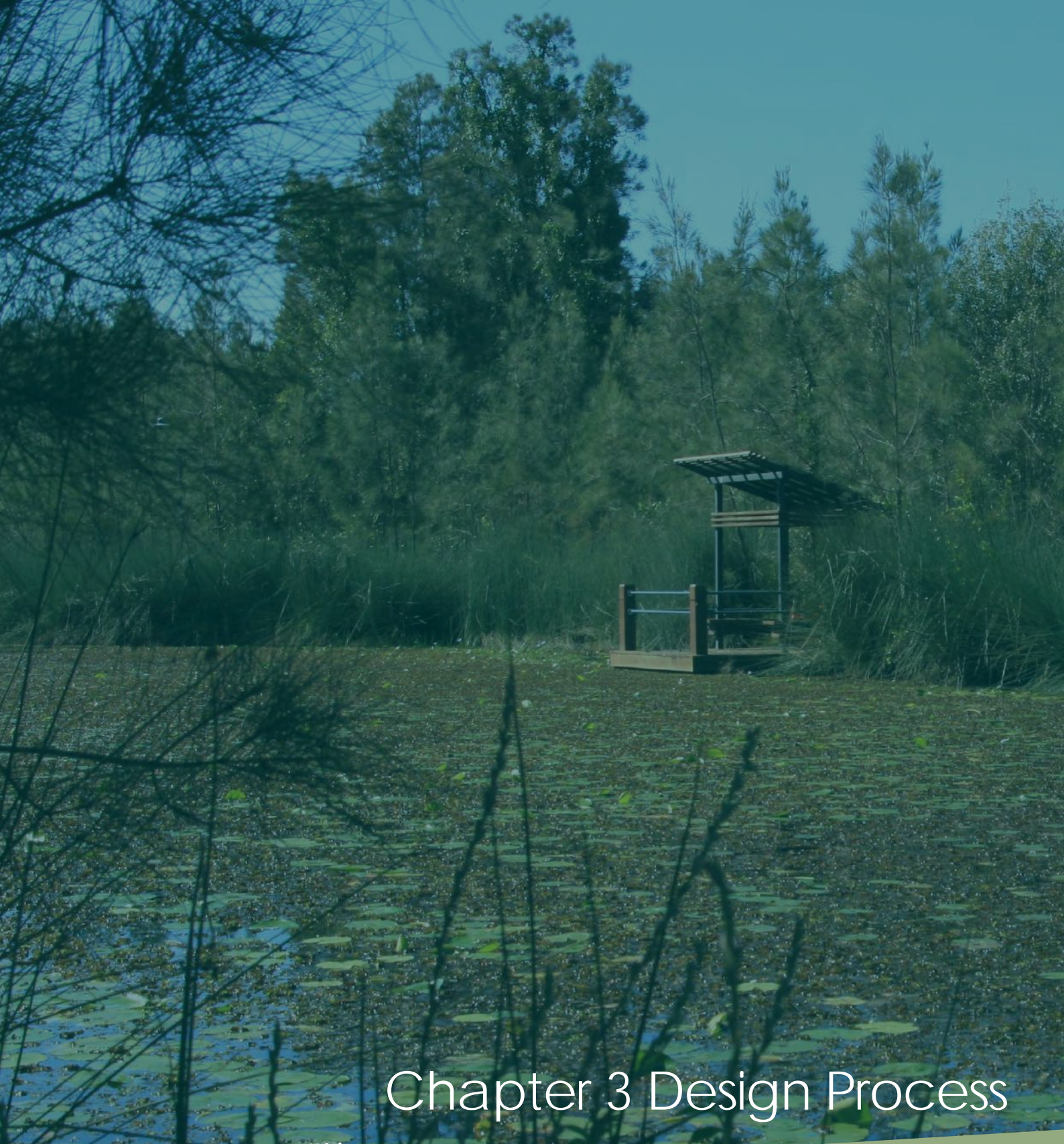

Chapter 3 Design Process

Photo: Paul Dubowski BMT WBM

Chapter 3 Design Process

The design of a constructed wetland in the urban context is a process that requires the civil, landscape and ecological aspects of the site to be considered and integrated. A successful design process ensures that wetlands are assets that achieve a range of benefits for ecosystems, residents and the asset owner including functionality, good integration with the urban landscape, contribution to local ecology and provision of benefits to nearby residents. Constructed wetlands involve multiple stages and

iterations as illustrated in **Figure 4**. The concept design phase involves selecting the most appropriate treatment measure, and identifying the location, size and indicative shape of the treatment system within the site. The Concept Design Guidelines for *Water Sensitive Urban Design* (Water by Design) should be used to guide the concept design phase. These concepts form the basis of detailed design, described in this document.

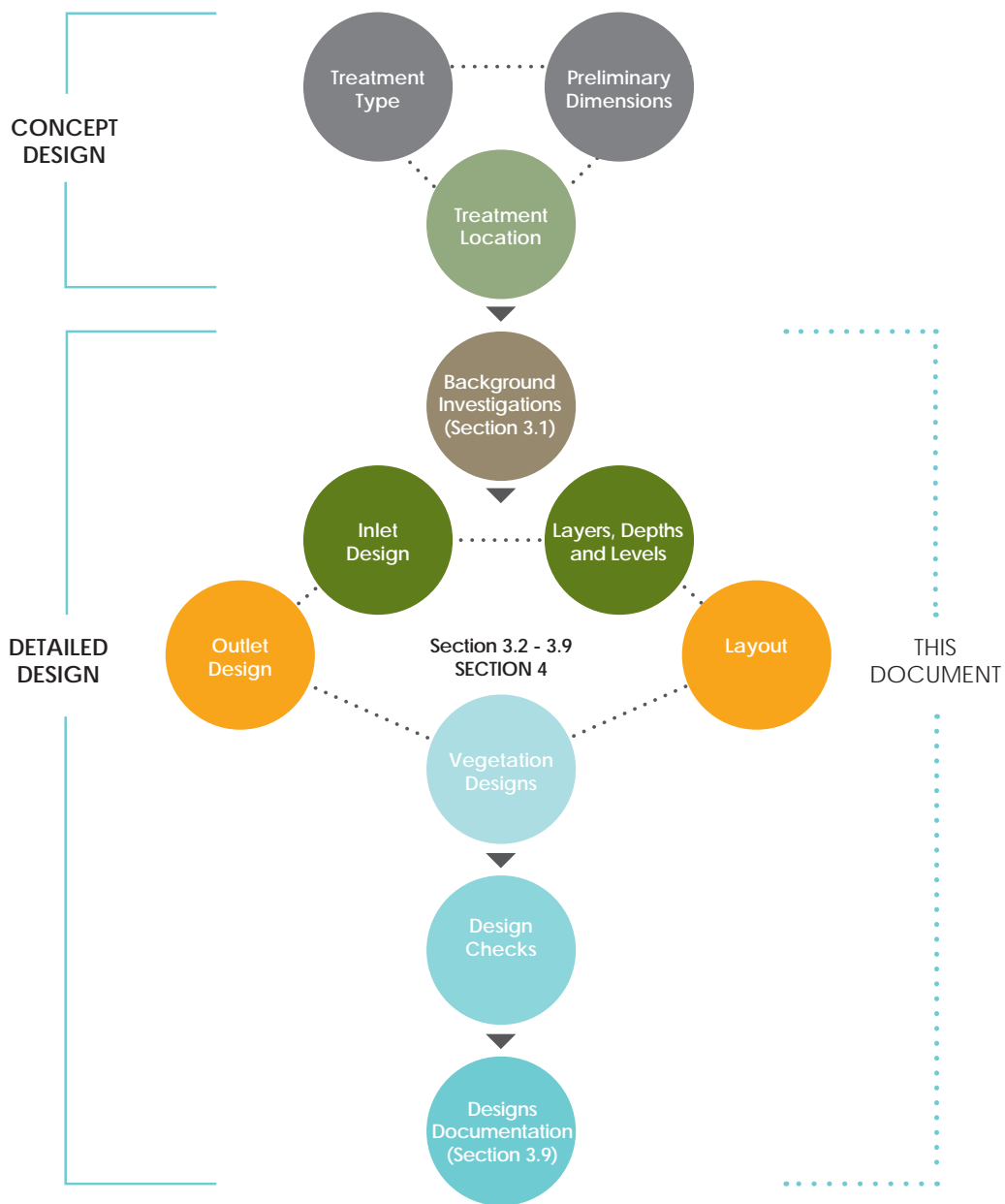

FIGURE 4 Wetland design process

3.1 Background investigations

Background investigations are required to ensure that site-specific opportunities and constraints are identified early in the design process, and incorporated into the constructed wetlands design. Undertaking the necessary background investigations streamlines the design process, reduces delays and mitigates risk during design, construction, establishment and operation. The background investigations required are:

- Analysis of the site
- Defining design objectives
- Consulting with the local authority.
- Required development assessments and approvals (e.g. stormwater management plan as part of a development application for reconfiguration, or operational works for an urban purpose resulting in the disturbance of greater than 2500 m²)

3.1.1 SITE ANALYSIS

To achieve a good design outcome, the constraints and opportunities of a site need to be both understood and tested with solutions that respond to these.

PERFORMANCE OUTCOMES

The results from the site analysis must be reported and demonstrate:

- An understanding of the site's constraints and opportunities
- That any assumptions made during concept design have been tested
- Inform the detailed design of the wetland.

RECOMMENDED APPROACH

Site information should be obtained using desktop analysis and site investigations. All members of the design team should visit the site. Team members are likely to have visited the site during concept development; however, a site visit is still recommended at the start of the detailed design phase, to verify the suitability of the concept and to collect more detailed information. Ideally, the whole design team should attend an initial site inspection to develop a clear understanding of the intent of the constructed wetlands' design, within context of the site.

The amount and quality of information required for detailed design will vary between projects. Table 5 summarises the information typically required from site analysis to begin detailed design. This information should be collected digitally and presented on an annotated plan.

TABLE 5 SITE INFORMATION REQUIREMENTS

INFORMATION	REQUIREMENTS	PRIMARY RESPONSIBILITY
<p>Topographical site survey</p>	<p>Survey the site and external areas (where applicable) to assess existing flow pathways.</p> <p>Survey the size, location, and levels of existing drainage and waterway features upstream, within, and downstream of the site. Importantly, invert levels of drainage systems that will receive outflows from the constructed wetland should be collected as well as the levels of any existing upstream contributing drainage.</p> <p>If water is ponding in these drainage systems, survey the water level after rainfall. Confirm seasonal variation in water levels, particularly in low-lying areas.</p> <p>Where the constructed wetland will connect with or abut future drainage infrastructure, the latest infrastructure plans could be consulted in lieu of a survey but preference is to complete survey.</p>	<p>Surveyor</p>
<p>Boundaries</p>	<p>Determine boundaries of existing and proposed road reserves and allotments and any access routes that may cross the constructed wetland. Consider if boundaries or routes are fixed or if there is scope to amend them.</p>	<p>Surveyor</p>
<p>Catchments</p>	<p>Determine the catchment area from a topographic survey or drainage network plans.</p>	<p>Stormwater specialist</p>
<p>Hydrology and drainage infrastructure</p>	<p>Inspect the site, waterways, constructed wetlands catchment and receiving drainage during and after rainfall to verify:</p> <ul style="list-style-type: none"> • flow direction and behaviour • presence of baseflow • ponded water zones (e.g. natural wetlands) • wetland discharge locations 	<p>Stormwater specialist, civil engineer, surveyor</p>
<p>Services</p>	<p>Always, identify existing services by undertaking a 'Dial Before you Dig' search (www.dialbeforeyoudig.com.au). Include the depths, locations, sizes and types of underground services on the site survey plans. Physical detection of underground services may be required.</p>	<p>Civil engineer</p>
<p>Flora and fauna</p>	<p>If a site contains individual plants or vegetation communities that are to be preserved, survey their size, location, level and drip zone.</p> <p>Review any flora and fauna reports for the site and receiving waterways.</p> <p>Identify locally occurring native plant species that are performing well in similar conditions to the conditions of the proposed constructed wetland.</p> <p>Identify the extent and location of invasive weeds that may influence design as well as any planting combinations that are successfully suppressing weeds.</p>	<p>Ecologist, surveyor</p>

INFORMATION	REQUIREMENTS	PRIMARY RESPONSIBILITY
Soil and Geotech	<p>Identify details of the site's soils (type, chemistry and structure) through previous investigations (concept design stage), a review of soil maps, or a soil assessment in accordance with AS/NZS 1547:2000 Clause 4.1.3.</p> <p>Undertake a preliminary desktop assessment for acid sulphate soils (ASS) or contamination. If there is a potential risk, further geotechnical investigations are required to ensure these soils are avoided or appropriately managed.</p> <p>All soils and geotechnical assessments, including management plans for ASS or contaminated soils, must be developed by a suitably qualified soil scientist or geotechnical engineer.</p>	Stormwater specialist and soil scientist
Groundwater	<p>Determine the general characteristics of the local groundwater. Ensure the constructed wetlands will not cause adverse impacts or be impacted (e.g. persistently high water levels, draining local groundwater, acid sulphate impacts)</p> <p>Preliminary assessment of groundwater should be undertaken at the same time as the soil assessment. Where elevated or acidic groundwater is detected, further groundwater investigations may be required to ensure the system does not interact with the groundwater (i.e. liner requirements). This work should be undertaken by a suitably qualified engineer or hydrogeologist.</p>	Stormwater/ WSUD specialist, soil scientist, hydrogeologist.
Landscape features and integration issues	<p>Interpret existing landscape features and, where relevant, survey these features. Features may include:</p> <ul style="list-style-type: none"> • topography • existing public safety or amenity issues • pedestrian and vehicle circulation and access points view corridors • the character and nature of any adjacent development and land use. 	Landscape architect

3.1.2 DESIGN OBJECTIVES

PERFORMANCE OUTCOMES

The design objectives for constructed wetlands must:

- be clear, align with local policy, and be agreed to by project team
- reflect landscape, engineering, and ecological considerations and requirements

RECOMMENDED APPROACH

Design objectives should be confirmed and agreed to by the design team, the client, and the government authorities.

Constructed wetlands must have at least two essential (primary) design objectives and one or more secondary design objectives. Design objectives often form part of land development policies and approval conditions. Examples of constructed wetland design objectives are:

- improve stormwater quality (typically the primary objective, in line with state or local government policies for the environmental protection of receiving waters)
- manage the rate and frequency of minor stormwater flows
- introduce a landscape feature into an urban setting
- enhance ecological values (i.e. increase local biodiversity)
- buffer or integrate with an existing bushland or riparian corridor to enhance degraded conditions
- facilitate passive landscape irrigation
- engage and educate the community.

Design objectives tend to change depending on adjacent land use (refer **Figure 5**). Objectives will dictate or influence particular design details. For example, if the primary objective of the constructed wetland is stormwater quality and a secondary objective is linking it to an existing riparian zone, then the system will have plants that integrate with the existing riparian vegetation communities.

For more information on objectives for wetland design refer to the *Living Waterways Framework* (Water by Design).

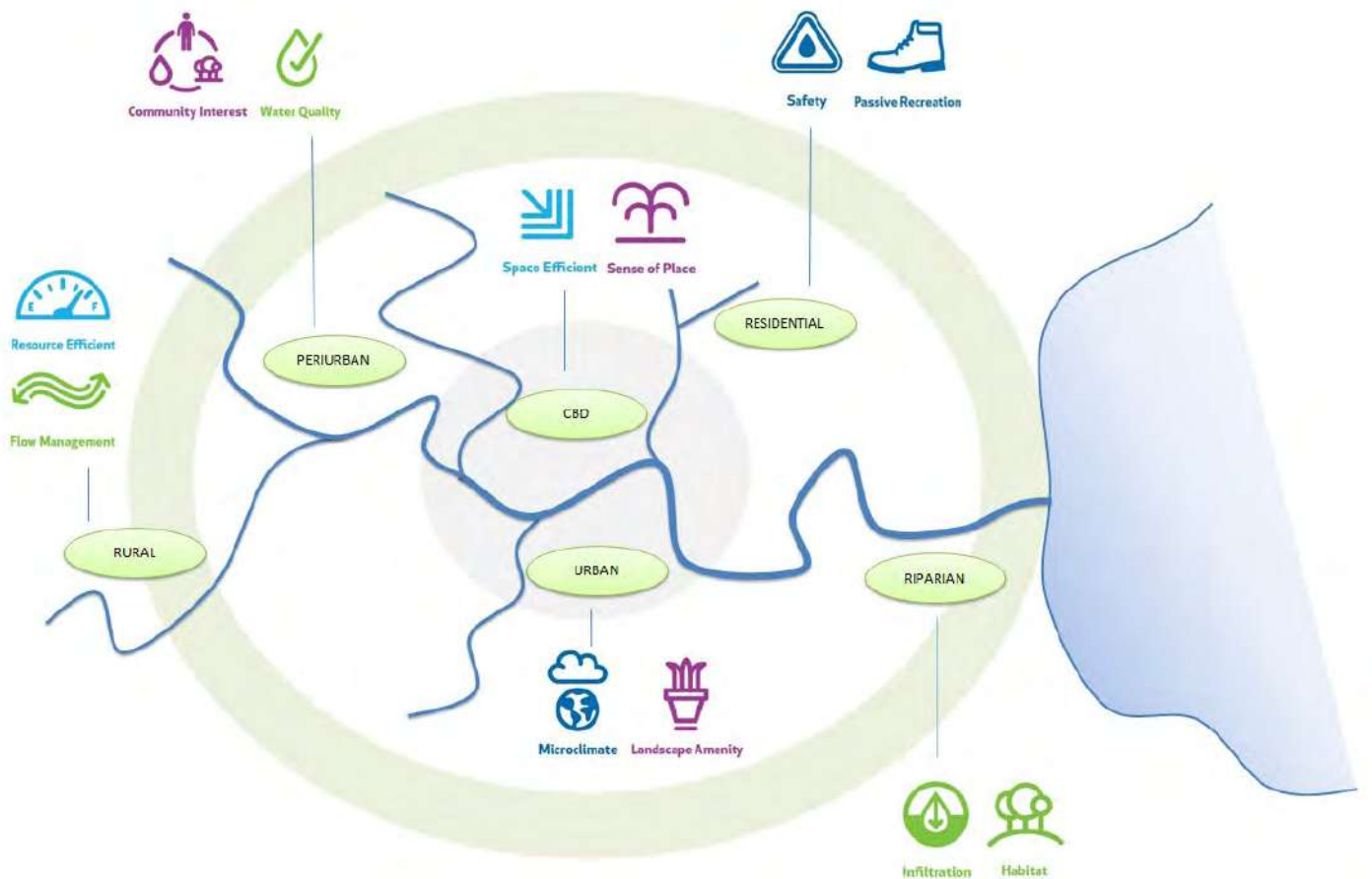

FIGURE 5 Example design objectives

3.1.3 LOCAL AUTHORITY CONSULTATION

PERFORMANCE OUTCOMES

The local authority's requirements and preferences for constructed wetland design, construction, and maintenance must be understood and information provided that demonstrates how this is incorporated into the design process.

RECOMMENDED APPROACH

Local authorities should be consulted early in the design process to discuss the intent and purpose of the constructed wetland. Local authorities will often be the ultimate owners of constructed wetlands that are, for example, handed over to the local authority by developers as contributed assets. Therefore, it is important that issues such as maintenance requirements are understood from the start.

The following information should be discussed with the local authority:

- relevant standard drawings
- formal or informal policies relating to constructed wetlands
- biodiversity issues and opportunities
- constructed wetland flood immunity requirements
- maintenance approach including bird management and vermin control
- access requirements
- physical constraints on maintenance techniques (e.g. excavator reach length)
- level of service
- budget
- problems with existing systems

Design Note: Development staging and asset handover impacts on wetland design

It is important to identify the local authority requirements for accepting contributed stormwater assets as part of development. Authorities will generally not accept poorly constructed, unfinished, damaged, or unestablished vegetated stormwater assets that are still subject to significant disturbance by construction and building activities in the catchment.

Therefore, the design of constructed wetlands in large developments should take account of the proposed staging and desired timing for compliance and asset handover processes. Multiple smaller constructed wetlands rather than a single, larger system may avoid potential issues associated with multi-stage developments.

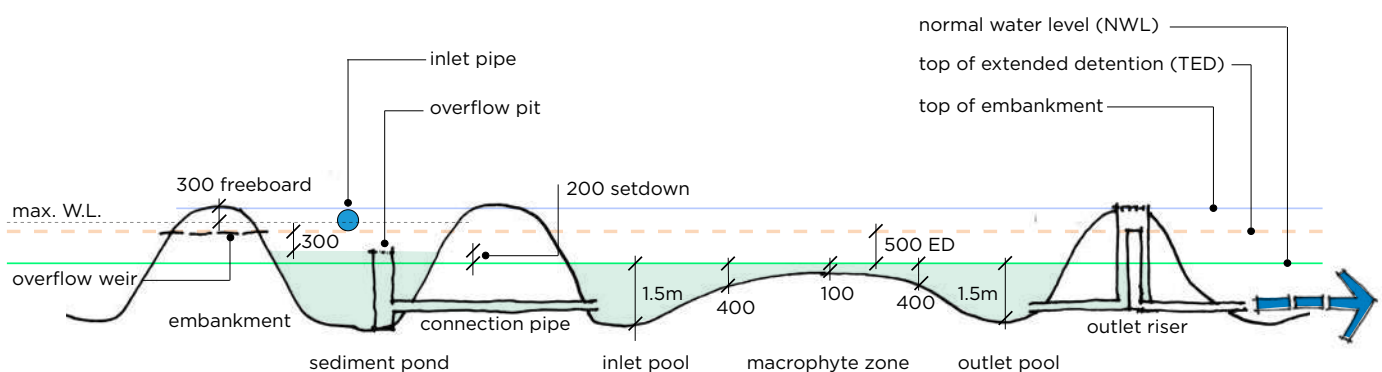

FIGURE 6 Extended detention depth and maximum water level requirements

3.2 Wetland Levels

In order to operate effectively, the levels of each of the wetland components need to be defined to confirm hydraulic function and inform the wetland layout (refer **Figure 6**). The design of the wetland levels are dictated by site constraints (see **Section 3.1.1**) and design objectives (see **Section 3.1.2**). Several design iterations of wetland levels may be needed to satisfy all engineering and landscape requirements.

The following components should be considered when setting wetland water levels:

- normal water level
- outlet pipe level

- extended detention depth
- maximum water level
- top of embankment level
- minimum embankment level

When setting wetland levels, the risks associated with shallow groundwater and tidal influences should be considered. Where possible, wetland systems should avoid any actual acid sulphate soils (AASS) or potential acid sulphate soils (PASS). If it is not possible to avoid AASS or PASS, expert advice should be sought to manage the risks.

Design Note: Estimating preliminary levels

It is important to carefully consider constructed wetland levels early in the design process and to make appropriate allowances for any constraints that may be encountered as the design progresses. Constraints in constructed wetland levels can impact development earthwork levels. Allow for a contingency in preliminary estimates of constructed wetland levels to avoid problems associated with raising development levels late in the design process. It is generally easier to convince a client to reduce development levels than increase them.

3.2.1 NORMAL WATER LEVEL

PERFORMANCE OUTCOMES

Wetland water level/s must comply with the following conditions:

- The wetland normal water level/s should be set as close to existing site levels as possible to minimise earthwork costs
- The macrophyte zone's normal water level should be set equal to or lower than the sediment basin's normal water level
- The wetland normal water level should be greater than the invert or ponded water level in the receiving drainage infrastructure, waterway (see **Section 3.2.2** for setting the outlet pipe levels) or tidal levels (refer **Section 3.2.3**).

RECOMMENDED APPROACH

The wetland zone normal water level can be set by working back from the invert levels or ponded water levels in the receiving drainage system. This is most effectively done by developing a drainage cross-section diagram which considers:

- Invert levels or ponded water levels in receiving drainage or waterway.
- Outlet pipe levels (refer to **Section 3.2.2**)
- Level changes in the outlet structures (which depends on the outlet structure used (typically 300-400 mm) including allowance for a valve to drain the wetland pools)

The normal water level in the wetland should be set sufficiently above (i.e. > 0.5 m) the receiving drainage or waterway to allow the water level in the wetland to be drawn down via gravity. This ensures the planted zones of the wetland can be exposed during vegetation establishment and when maintenance is required. Where the normal water level is set less than 0.5 m above the receiving drainage or waterway, then pumping will be required to maintain a lower wetland water level during establishment. The local authority must be consulted in this case to confirm pumping is appropriate for the wetland.

TABLE 6 OUTLET PIPE LEVEL RECOMMENDATIONS

RECEIVING DRAINAGE SYSTEM	MINIMUM RECOMMENDED LEVEL
Ephemeral waterway	300 mm above waterway invert or 100 mm above wet season water level, whichever is highest
Perennial waterway	300 mm above dry weather water level or 100 mm above wet season water level, whichever is higher
Natural wetland	100 mm above the maximum of the ground level or wet season standing water level
Natural ground	100 mm above the maximum of the ground level or wet season standing water level
Pipe drainage system	50 mm above invert of downstream pit or pipe system and above wet season baseflow levels

3.2.2 OUTLET PIPE LEVEL

PERFORMANCE OUTCOMES

Outlet pipe levels must:

- allow the wetland to drain freely
- provide a minimum 0.3% grade so that accumulated sediment does not block the outlet pipe connection with the receiving drainage system

RECOMMENDED APPROACH

Constructed wetland outlets should drain freely to receiving drainage systems. The recommended outlet pipe grade is at least 0.3% (preferably $\geq 0.5\%$). The outlet pipe level is defined as the invert of the outlet pipe where it discharges into receiving drainage system. Minimum recommended outlet pipe levels (set downs) between the invert of the outlet pipe and the invert of different receiving drainage systems is provided in **Table 6**.

3.2.3 CONSTRUCTED WETLAND LEVELS RELATIVE TIDAL LEVELS

PERFORMANCE OUTCOMES

The wetland design must ensure that saline tidal water does not enter the wetland.

RECOMMENDED APPROACH

Allowing tidal water to enter the wetland will be detrimental to the wetland biota (e.g., aquatic plants, biofilms and invertebrates). Many aquatic plants are highly sensitive to saline water, and the intrusion of seawater into the wetland can result in widespread loss of wetland vegetation cover.

The wetland water level (i.e outlet level) must be set at or above the highest astronomical tide (HAT) level.

3.2.4 EXTENDED DETENTION DEPTH

PERFORMANCE OUTCOMES

The extended detention depth should be:

- equal to or less than 0.5 m depth
- not harm the wetland vegetation through excessive inundation depth

RECOMMENDED APPROACH

The wetland extended detention depth is likely to have been determined during the concept design phase as it is integral to modelling the wetland treatment performance.

The extended detention depth must be equal to or less than 0.5 m, particularly for macrophyte based wetlands.

Design Note

Alternative wetland styles such as ephemeral melaleuca wetland systems may be able to survive under greater than 0.5m extended detention. Extended detention depth of greater than 0.5 m will only be considered where detailed inundation frequency and duration has been completed by an experienced hydrologist and wetland ecologist to confirm the proposed plants can survive.

3.2.5 MAXIMUM WATER LEVEL

PERFORMANCE OUTCOMES

- The maximum wetland water level should not exceed more than 0.3 m above the top water level (top of extended detention)
- be set at the 100yr ARI water level where the wetland is combined with a flood storage

RECOMMENDED APPROACH

The maximum water level in the wetland will be controlled by the inlet arrangement to the macrophyte zone (connection between the sediment basin and the macrophyte zone) and the size of the macrophyte overflow weir. The maximum wetland water level should be assumed to be 0.3 m above the top water level (i.e. 0.3 m surcharge depth over the overflow weir).

Where the wetland is combined with a flood storage to attenuate local flows, water levels will rise above the extended detention depth for short periods. The maximum water level will be the 100yr ARI flood level in the flood storage which will be set through hydrologic/hydraulic modelling.

3.2.6 REGIONAL FLOODING IMMUNITY

PERFORMANCE OUTCOMES

The embankment level must be suitably high to ensure the constructed wetland will not be subject to unacceptable damage as a result of regional flooding (i.e. flooding from regional rivers, creeks or drainage systems with significantly larger catchments than the constructed wetland).

RECOMMENDED APPROACH

Stormwater treatment systems must be protected from future damage resulting from flooding of regional rivers and local waterways which convey stormwater derived from large catchments and external development. Protection must be provided in the form of flood immunity as per below:

- Top of embankment > 1 year ARI regional flood level
- Inundation period <3 days
- Velocity over surface in 5yr <0.5m/s and 100yr < 1m/s
- Where outside of embankment velocities <1m/s scour protection may be required

The outlet levels of the wetlands and the required hydraulic levels through the system will typically mean the embankment level will meet these requirements. Appropriate hydraulic modelling will be required to confirm the regional flood levels, velocities and inundation periods. Where the wetland is potentially prone to high velocity, the local authority reserves the right to request a geomorphic assessment to confirm the embankment will be stable and will not cause erosion within the adjacent waterway.

3.2.7 TOP OF EMBANKMENT

PERFORMANCE OUTCOMES

The top of embankment level should:

- contain the maximum water level with appropriate freeboard (i.e. 0.3m freeboard)
- prevent the constructed wetland from being damaged by flows from external catchments and regional flooding

RECOMMENDED APPROACH

The top of embankment should be set:

- 0.3 m above the maximum water level in the wetland (refer to **Sections 3.2.4** and **3.2.5**)
- At or above the regional flood immunity requirements (refer **Section 3.2.6**)

The top of embankment needs to be a consistent level around the entire wetland to ensure that water from the wetland cannot discharge over low points in the embankment.

Where constructed wetlands are located within a flood storage, the wetland embankment level may be dictated by flood storage requirements of the flood storage. A low embankment may also be constructed around the wetland within the flood storage to protect the wetland from regular flood events (i.e. up to the 1 year ARI).

3.2.8 SEDIMENT BASIN LEVELS

PERFORMANCE OUTCOMES

The sediment basin design must:

- have a water level equal to or greater than the water level in the macrophyte zone
- provide sufficient storage depth to enable coarse sediments to be trapped and stored
- ensure that the inlet pipes are at normal water level or partially submerged

RECOMMENDED APPROACH

The sediment basin water level should be set at or up to 0.2m above the normal water level of the wetland. This allows the macrophyte zone to provide “feedback” when the extended detention volume is full and enable additional inflows to the sediment basin to be discharged into high flow bypass channel (i.e. macrophyte zone riser controls flows to top of extended detention then high flow weir starts to discharge).

In some cases the sediment basin water level may need to be set higher than these recommendations. If this is the case then careful design of the hydraulic connection to the macrophyte zone and a weir in the macrophyte zone will be required (refer **Section 3.5.7.4**).

The base of the sediment basin should be at least 1.5 m below the NWL to provide sufficient depth to trap (0.5 m) and store (1.0 m) coarse sediments.

Inlet pipes to the sediment basin should ideally be at water level. Hydraulic calculations for the upstream stormwater drainage network should take into account the maximum water level in the sediment basin.

3.2.9 WATER LEVEL INDICATORS

PERFORMANCE OUTCOMES

Provide a rapid visual method for assessing the water level in the wetland against the normal water level.

RECOMMENDED APPROACH

A water level marker (or water depth gauge) must be installed to show the wetland water level relative to normal water level. The marker must be able to be read from the bank and ideally attached to the headwall of the hydraulic connection to the macrophyte zone.

3.3 Wetland Layout

Whilst constructed wetlands play a significant role in delivering stormwater quality objectives, they can also play an important role in creating community landscapes and urban ecology. The following sections outline some of the design issues that should be considered when designing the layout of constructed wetlands.

The layout of the constructed wetland should ensure that sufficient space is allocated for all elements of the system, that the location and design of these elements does not compromise the amenity or function of the surrounding spaces and infrastructure. The layout of the constructed wetland should consider the:

- shape and location of the constructed wetland
- macrophyte zone length to width ratio to ensure plug flow through the wetland (length \geq 4 times average width)
- inlet and outlet locations
- wetland edge and landscape interface
- maintenance access
- underground services
- road reserves
- flood storage requirements

Numerous opportunities are available for creative design solutions for specific elements. Close collaboration between landscape designer, hydraulic designer, civil/ structural engineer and maintenance personnel is essential. In parklands and residential areas, the aim is to ensure elements are sympathetic to their surroundings and are not overly engineered or industrial in style and appearance. Additionally, landscape design to specific elements should aim to create places that local residents and visitors will come to enjoy and regard as an asset.

3.3.1 FUNCTIONAL SHAPE AND LOCATION

PERFORMANCE OUTCOMES

The shape and location of constructed wetlands must:

- place the sediment basin to accept inflows from the catchment
- ensure the macrophyte zone length is \geq 4 times average width to promote plug flow
- ensure the system is suitably integrated with the landscape and considers the site's constraints
- allow the system to be easily constructed with commonly available equipment, without compromising the system's ability to meet its design objectives.

RECOMMENDED APPROACH

To ensure the water quality performance of the constructed wetland is achieved, there are a number of functional layout and shape requirements which must be achieved:

- sediment basin must be located at the inflow discharge location from the catchment
- macrophyte zone must promote plug flow by ensuring the length is \geq 4 times average width
- inflow from the sediment basin must enter at one end of the macrophyte zone length (via the macrophyte zone hydraulic connection) and exit at the opposite end of the length (via the macrophyte zone outlet)
- the end of the macrophyte zone and macrophyte outlet needs to be located as close as possible to the discharge point in the receiving drainage system
- the high flow bypass must connect from the sediment basin high flow bypass weir to the waterway or floodplain in an efficient manner to minimise land take
- maintenance tracks, embankments and batters must be allowed for when establishing location and space the constructed wetland

Further guidance on each of the functional requirements is provided in **Sections 3.4** and **3.5**.



FIGURE 7 Wetland in a natural setting

Photo by Glenn Browning – Healthy Land and Water

3.3.2 LANDSCAPE INTEGRATION

PERFORMANCE OUTCOMES

The shape and location of constructed wetlands must ensure the system is suitably integrated with the landscape and considers the site's constraints.

RECOMMENDED APPROACH

Features surrounding constructed wetlands have an important role in defining the overall shape and edge design of the system. Existing features often need to be preserved and are therefore an important constraint to the layout of constructed wetlands. Features in the surrounding area that will be created or modified in the future also need to be considered, and their value to the environment and community protected and enhanced. These features may include:

- vegetation or trees
- local topography
- waterway and associated riparian zone
- pedestrian paths or roads
- residential dwellings
- playgrounds and active parks.

For systems in natural settings the planting palette should complement the existing vegetation (refer **Figure 7**). For systems in parks, the approach must allow for the provision of places in and around the

wetland where activities such as picnics, passive and active recreation (e.g. kick-around spaces) and sightseeing can be enjoyed. For systems in civic spaces (**Figure 8**), shade, seating and ease of movement for large groups of people must be provided. The design of the shape and location of a constructed wetland must provide a solution that:

- manages the aesthetics of engineering and maintenance infrastructure such as headwalls, inlets, outlets, weirs, access tracks bunds and batters
- considers the visual amenity of the sediment basin which at certain times will have poor water quality and litter
- ensures the shape of the constructed wetland is appropriate for the site, for example an organic, curved shape is generally suitable for natural settings while a more rigid, angular shape is better suited to built up areas
- provides scenic views and important pedestrian and vehicle sight lines with trees and shrubs (i.e. locate deep pools in visible locations)
- considers the impacts from overflows
- manages the influence of overshadowing from tall trees
- considers implications on park circulation and pedestrian use patterns.

Design Note: Existing vegetation

Wetland earthworks should avoid the critical root zone (typically defined as 500 mm beyond the vegetation's drip line) of any retained vegetation (e.g. trees). Advice should be sought from an arborist regarding earthworks close to trees. Refer also to AS4970 – 2009 Protection of trees on development sites.

FIGURE 8 Wetland in an urban setting

Photo by Robin Allison - DesignFlow



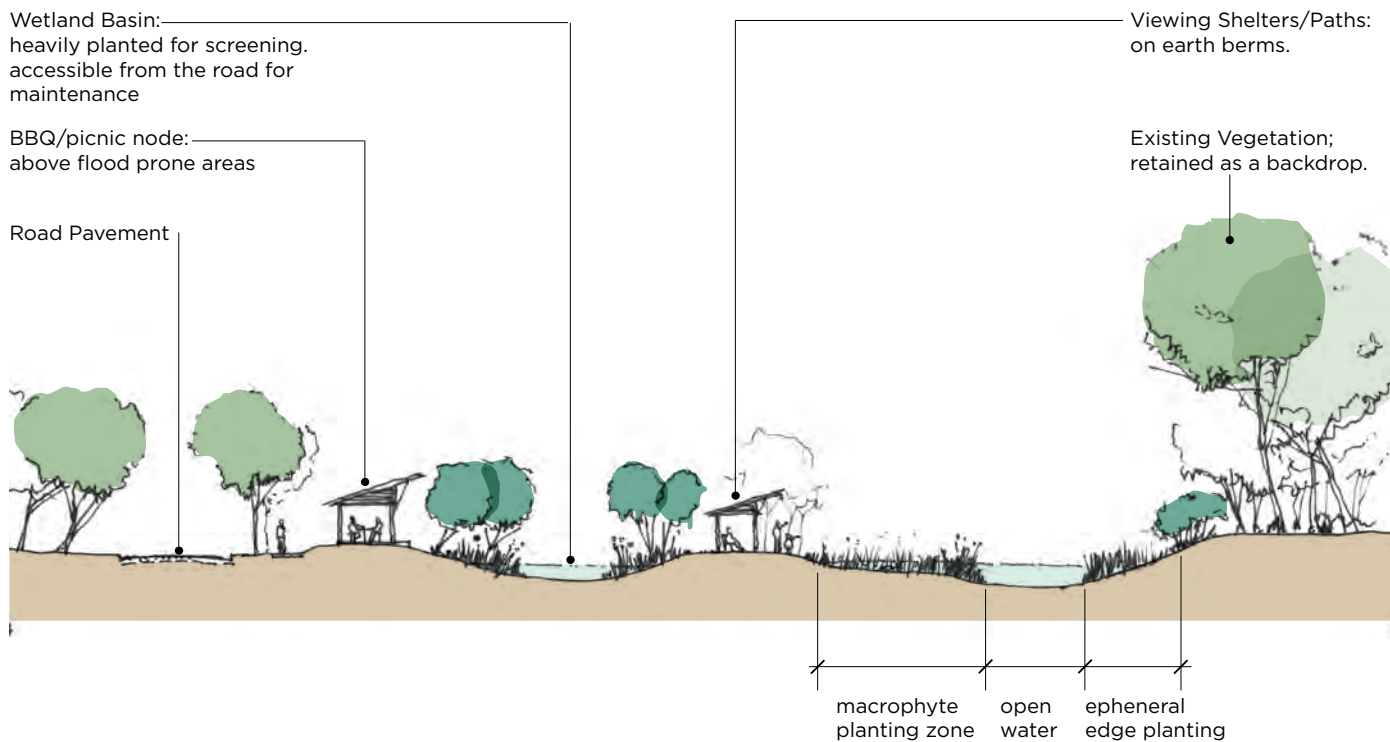

FIGURE 9 Typical landscape treatments to constructed wetlands in open space areas

3.3.3 PUBLIC ACCESS

PERFORMANCE OUTCOMES

The constructed wetland design and layout must demonstrate that:

- there is legible and meaningful connection with adjacent public spaces including parks, roads and adjacent private property
- public access is promoted through safe, and meaningful linkages and pathways

RECOMMENDED APPROACH

The shape and form of constructed wetlands should integrate with adjacent active and passive public spaces. Interaction with pedestrian and vehicle pathways, and Crime Prevention Through Environmental Design principles should guide landscape design for constructed wetlands in these situations.

Opportunities to enhance public amenity and safety with viewing areas, pathway links, picnic nodes, interpretive signage/art and other elements should

be explored to further enhance the social context of constructed wetlands (refer **Figure 9** to **Figure 12**) Apart from often being a council requirement, constructed wetland design that generates value in this way can also save money by creating opportunities for integration with creditable open space. Refer to the Living Waterways Framework (Water by Design) and the framework for public open space (Water by Design) for more information on incorporating these elements into wetlands.

Providing access to and around constructed wetlands using pathway crossings and boardwalks over constructed wetlands allow the public to interact with and develop an appreciation of such systems, but can be expensive (**Figure 13**). Solid embankment crossings with culverts to allow water to pass underneath are generally cheaper to construct than boardwalk or bridge style crossings.



FIGURE 10 Viewing platform

Photo by Jack Mullaly – Ideanthro



FIGURE 11 Wetland shelter

Photo by Paul Dubowski – BMT WBM



FIGURE 12 Interpretive signage

Photo by Brad Dalrymple – BMT WBM



FIGURE 13 Boardwalk over constructed wetland

Photo by Robin Allison - DesignFlow

TABLE 7 CONSTRUCTED WETLAND INTERFACE WITH UNDERGROUND SERVICES

SERVICE	ACCEPTABLE LOCATION RELATIVE TO CONSTRUCTED WETLAND
<p>Electrical, telephone, gas</p>	<p>Electrical, telephone and gas services should not be located in the constructed wetland’s treatment zone</p> <p>They can be located under batters</p> <p>Detection tape and kerb markers should be used to show service locations</p> <p>Service connections (electrical pillars etc.) in wetlands are not recommended</p>
<p>Water, sewer, stormwater</p>	<p>Water, sewer and stormwater services should not be located within the treatment zone</p> <p>They can be installed under batters. In difficult or constrained situations it may be possible to locate sewers or stormwater infrastructure under the wetland treatment zone</p> <p>Detection tape and kerb markers should be used to show service locations. Service connections (water meters etc.) in the treatment zone are not recommended.</p>

3.3.4 UNDERGROUND SERVICES

PERFORMANCE OUTCOMES

The design of constructed wetlands must demonstrate that:

- the operation of the constructed wetland does not compromise the function of underground services and vice versa
- common maintenance and checking activities undertaken on the service do not compromise any component or function of the constructed wetland, or vice versa.

RECOMMENDED APPROACH

Underground services should be located outside the treatment area, but may be incorporated into wetland batters. Where this is not possible (e.g. in retrofit), how to access services for maintenance without regularly disrupting the wetland should be considered.

Interactions between services and the constructed wetland are detailed in **Table 7**; however, the requirements of local authorities and service providers take precedence over the advice in **Table 7**.

A Dial Before You Dig investigation should be undertaken to identify all existing services within the vicinity of the wetland. Where a Dial Before You Dig investigation identifies the presence of services, pot holing and survey of the service must be undertaken, considered in the design and included on design drawings.

3.3.5 WETLANDS CONSTRUCTED WITHIN FLOOD STORAGE

PERFORMANCE OUTCOMES

When constructed wetlands are combined with flood storage (i.e. flood detention basin to manage peak flows), they must ensure that:

- flood storage outcomes are achieved
- flood storage design does not rely on extended detention volumes
- wetland vegetation is not inundated for extended periods of time (typically more than 3 days)
- constructed wetland design objectives are not compromised during or after flood events

RECOMMENDED APPROACH

Constructed wetlands may be integrated into the base of flood storage, effectively reducing the overall land required for managing stormwater quality and quantity. Where constructed wetlands can be integrated into the base of flood storage, they will infrequently become inundated to greater depths than the extended detention depth. The duration of any inundation should be relatively short (hours) and is unlikely to affect the vegetation in the constructed wetland if the water can drain after flood events without causing scour in the macrophyte zone and batters and does not deposit excessive sediment within the macrophyte zone.

The size and configuration of the flood storage should be carefully defined and integrated with the broader landscape. The flood storage area outside the constructed wetland can be flat or sloped, depending on the site characteristics and proposed vegetation. The flood storage size should be established using modelling and calculations in accordance with local authority standards.

When designing a wetland within a flood storage, the outlet control structure of the flood storage (typically culverts) should be placed at the end of the wetland

bypass channel. This ensures flood flows 'backwater' across the wetland thus protecting the macrophyte vegetation from scour by high velocity flows.

A number of issues should be considered when combining flood storage with constructed wetland systems:

- Extended detention volume should not be included in the storage volume used to assess the performance of flood attenuation. The extended detention is drawn down via the outlet riser at a slower rate than the dedicated flood storage volume. This means the extended detention volume is not available for flood storage if a flood event closely follows a smaller rainfall event.
- Where a constructed wetland is sized to meet the objectives for a catchment that is smaller than the total flood storage catchment, flows from the additional flood storage catchment greater than the peak one-year Average Recurrence Interval (ARI) event should bypass the macrophyte zone. This will avoid overloading the treatment zone with sediment.
- To minimise the risk of scour, the spread of flows greater than the peak one-year ARI should be controlled by the flood storage outlet (i.e. backwater).
- Where suitable land is available, the peak 20-year ARI inundation depth should be no more than 1.2 m deep (where possible) in accordance with QUDM (DEWS, 2013).
- Walls should not be used around the perimeter of the constructed wetland to avoid a vertical drop that will be hidden when the flood storage is engaged.
- The surface of the flood storage that will be inundated by the peak one-year ARI water level should be vegetated with appropriate plant species (i.e. not turf) as it will be frequently wet and mowing is likely to be difficult.



FIGURE 14 – Floating wetland

Photo by Glenn Browning – Healthy Waterways

3.3.6 FLOATING WETLANDS

Floating wetlands are an emerging technology that may assist with stormwater treatment. Whilst floating wetlands have been used for various water treatment applications (e.g. wastewater), the use of floating wetland for stormwater quality treatment is less well understood and currently subject to investigation. Floating wetlands usually consist of a buoyant mat, an organic growing media and plants (**Figure 14**). The roots of the plants are suspended in the water below the floating mat. Stormwater is then treated via biofilms that form on the plant roots and via direct uptake from the plants.

Advantages of floating wetlands include:

- Easy to retrofit into ponds or lakes
- Shading of water surface can lower water temperatures
- Floating wetland systems may be suitable for stormwater harvesting ponds where there are large water level fluctuations
- Floating wetlands are scalable and can have a customizable shape

- High sediment loads will not smother the wetland plants
- Floating wetlands may act as a habitat for fish, birds and other wildlife

Some design considerations include:

- There may be low dissolved oxygen (and potentially anoxic conditions) when there are no flow conditions and this may affect waterway health – it is recommended to include open water zones (min 50% of surface area) to allow diffusion of oxygen
- Roots of plants may connect with soil on base of pond and this may result in submergence of plants when extended detention is engaged
- Floating wetlands need to be tethered so they don't move from position due to wind action
- Plant species need to be hardy species that tolerate wet roots (e.g. Carex)
- Netting may be required in early stages of plant establishment for protection against birds
- Infrequent harvesting of plants may be appropriate – although this is not a very effective long term method of nutrient load reduction

3.3.7 STORMWATER HARVESTING AND REUSE WETLANDS

Stormwater harvesting can be defined as the diversion, storage and treatment of stormwater runoff from urban catchments for beneficial reuse. Stormwater harvesting is a cost effective and environmentally positive source of water.

Urban stormwater flows can significantly impact the ecology of urban creeks and deliver damaging levels of pollutants to the receiving environment. Stormwater harvesting provides a double dividend by reducing these impacts, while providing a water supply source. It turns a problem into a resource.

Constructed wetlands can be configured as a **collection point** and **primary treatment** system for stormwater harvesting systems. Wetlands can also be used as a **temporary or permanent storage** for harvested water.

A couple of design issues need to be considered including:

- It is important to think about edge treatment if large fluctuations in water level are likely
- Large fluctuations in waterlevels can have a detrimental impact on plant health (both littoral edge and macrophyte zone)
- Use inundation frequency analysis (refer page 85) for guidance on estimating water levels and determining maximum draw down depth and water fluctuation

- It may be important to have a pump cutoff so that the wetland is not completely drained
- If edges are likely to be muddy and unsightly then screens (e.g. dense shrubs) may be needed so visual amenity is not affected
- It is also possible to have a separate pond on the tail end of a wetland for water storage. This can be hydraulically disconnected so that drawdown does not drain the whole wetland.
- Water proof liners to the storage pond are especially important to prevent leakage and prevent loss of yield. Shading the open water body will also reduce evaporation of the stored stormwater.
- Debris screens will be necessary on intake pipes to avoid blockage of irrigation pumps
- Water needs to be fit for purpose, full treatment may not be necessary for some applications (e.g. irrigation) however additional treatment (e.g. UV disinfection) may be necessary for other applications where human contact of the water is possible.

For further information refer to Water by Design's *Draft Stormwater Harvesting Guidelines 2009*.



FIGURE 15 Sediment Basin

Photo by Jack Mullaly - Ideanthro

3.4 Sediment Basin Design

The sediment basin of a constructed stormwater wetland is designed as a sedimentation basin and has two key functional roles. The primary role is to remove coarse to medium sized sediment (i.e. 125 μm or larger) prior to flows entering the macrophyte zone. This ensures the vegetation in the macrophyte zone is not smothered by coarse sediment and allows the macrophyte zone to target finer particulates, nutrients and other pollutants.

The second role of the sediment basin is to control and regulate flows entering the macrophyte zone and bypass flows during 'above design flow' conditions. The outlet structures from the sediment basin are designed such that flows up to the 'design flow' (typically the 1 year ARI) enter the macrophyte zone whereas 'above design flows' are bypassed around the macrophyte zone. In providing this function, the sedimentation basin protects the vegetation in the macrophyte zone against scour during high flows.

Note that when the available space for a constructed wetland is constrained, it is important to ensure that the size of the sediment basin is not reduced. This ensures the larger sediments are effectively trapped and prevented from smothering the macrophyte zone. When the site constrains the size of the constructed wetland it is the macrophyte zone of the wetland that should be reduced accordingly.

The following sections outline the design of:

- Design Flows
- Area
- Shape
- Depth
- Hydraulic connection to Macrophyte Zone
- Bypass Weir
- Scour protection

PERFORMANCE OUTCOMES

Sediment basins for constructed wetlands must be designed to:

- remove coarse sediment by using a permanent water column to reduce flow velocities and promote settling
- provide appropriate storage for coarse sediment to ensure desilting is only required infrequently
- regulate flows entering the macrophyte zone
- dissipate inflow energy
- allow for high flows to bypass the macrophyte zone and prevent scour
- minimise safety risk
- provide visual amenity.

RECOMMENDED APPROACH

The sediment basin of a constructed stormwater wetland is designed as a sedimentation basin and serves two functions: (1) pretreatment of inflow to remove coarse to medium sized sediment; and (2) the hydrologic control of inflows into the macrophyte zone and bypass of floods during 'above design' operating conditions. As depicted in **Figure 15** and **Figure 16**, the sediment basin consists of the following elements:

- Sedimentation basin 'pool' to capture coarse to medium sediment (125 μm or larger).
- Sediment basin connection to the macrophyte zone (or 'control' structure) normally consisting of an overflow pit within the sediment basin connected to one or more pipes through the embankment separating the sediment basin and the macrophyte zone.
- Normally domed grates are attached atop the control structure to minimise trash build up and potential blockage. This structure will need to be regularly maintained during operational phase.
- High flow bypass weir (or 'spillway' outlet structure) to deliver 'above design' flood flows to the high flow bypass channel.

When applying the design procedure outlined below, the following should be used as a guide:

- The sediment basin typically must comprise a deep open water body (typically 1.5 m to 2 m deep) that is essentially designed to capture coarse to medium sized sediment (i.e. 125 μm or larger).
- For high polluting catchments it may be necessary for a GPT or trash rack to be installed such that litter and large debris can be captured at the interface between the incoming waterway (or pipe) and the open water of the sediment basin (depending on local council requirements).
- The inlet and outlet structures should be located at opposite ends of the sediment basin and be aligned to promote a high hydraulic efficiency.
- The outlet (i.e. hydraulic connection from the sediment basin to the macrophyte zone) is typically an overflow pit and pipe. The crest of the overflow pit sets the water level and is at or maximum 0.2m above the normal water level in the macrophyte zone. The overflow pit must be accessible for maintenance and have a grate (preferably dome grate) for safety.
- The pipe that connects the sedimentation basin to the macrophyte zone needs to have sufficient capacity to convey a 1 year ARI flow, assuming the macrophyte zone is at the normal level and without resulting in any flow over the high flow bypass weir.
- For large wetlands, pipe or culvert can be used in place of the pit and pipe system. In this case the pipe invert needs to be at or just below normal water level to avoid accumulated sediment being resuspended and washed into the macrophyte zone.
- The sediment basin is to have a structural base (e.g. concrete) to define the base when desilting and provide support for maintenance plant/ machinery when entering the basin for maintenance.
- The high flow bypass weir ('spillway' outlet) is to be set at the same level as the top of extended detention in the macrophyte zone.

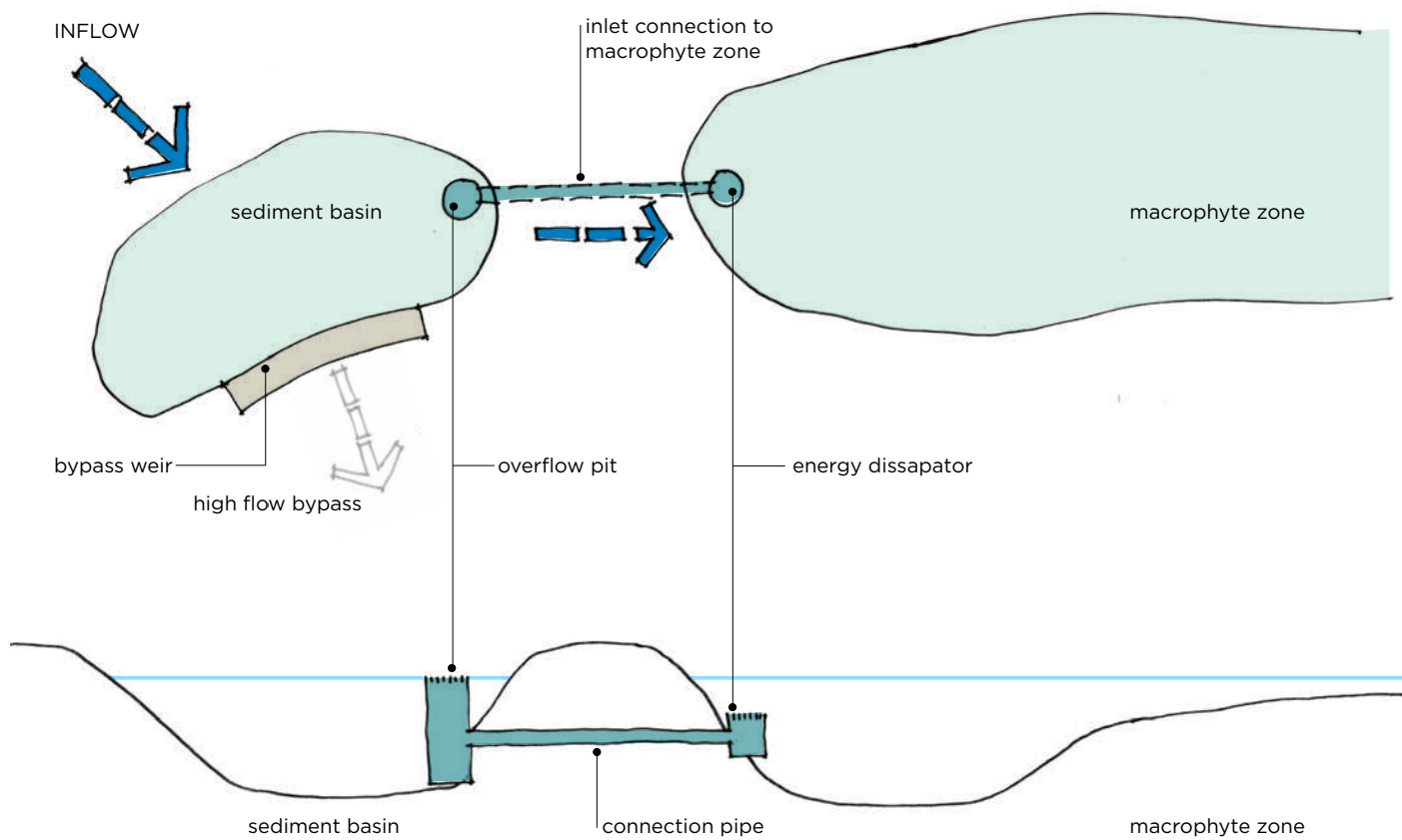

FIGURE 16 Example of sediment basin connection to macrophyte zone

3.4.1 DESIGN FLOWS

PERFORMANCE OUTCOMES

Stormwater infrastructure should be designed to safely convey 'design flows' to the macrophyte zone and 'above design flows' to the high flow bypass.

RECOMMENDED APPROACH

To configure the sediment basin and high flow bypass elements of a constructed wetland the following design flows apply:

DESIGN FLOW (1 year ARI) for sizing the sediment basin and the 'control' outlet structure (i.e. overflow pit and pipe connection) discharging to macrophyte zone.

ABOVE DESIGN FLOW for design of the high flow bypass around the macrophyte zone. The discharge capacity for the bypass system may vary depending on the particular situation but will typically correspond to one of the following:

- Minor design flow (2 or 10 year ARI) – For situations where only the minor drainage system is directed to the sediment basin. Relevant local government guidelines should be referred to for the required design event for the minor design flow.
- Major flood flow (100 year ARI) – For situations where both the minor and major drainage system discharge into the sediment basin.

A range of hydrologic methods can be applied to estimate design flows. If the catchment areas to the sediment basin are <50 ha, the Rational Method design procedure is considered to be a suitable method for estimating design flows. However, if the constructed wetland is to form part of a flood storage (**Section 3.3.5**) or if the catchment area to the wetland is large (> 50 ha), then a full flood routing computation method needs to be used to estimate design flows. Refer to QUDM (DEWS, 2013) for further information about peak flow estimation.

TABLE 8 SETTLING VELOCITIES (V_s) UNDER IDEAL CONDITIONS)

CLASSIFICATION OF PARTICLE SIZE	PARTICLE DIAMETER (μM)	SETTLING VELOCITIES (MM/S)
Very coarse sand	2000	200
Coarse sand	1000	100
Medium sand	500	53
Fine sand	250	26
Very fine sand	125	11
Coarse silt	62	2.3
Medium silt	31	0.66
Fine silt	16	0.18
Very fine silt	8	0.04
Clay	4	0.011

Source: (Maryland Dept. of Environment 1987 in Engineers Australia 2006)

3.4.2 AREA

The area of a sediment basin is an important parameter as it determines the quantity of sediment that can be captured.

PERFORMANCE OUTCOMES

Sediment basins are to have sufficient surface area

EQUATION 1

$$R = 1 - \left[1 + \frac{1}{n} \cdot \frac{V_s}{Q/A} \cdot \frac{(d_e + d_p)}{(d_e + d^*)} \right]^{-n}$$

Where

R = fraction of target sediment removed (typically 80-90%)

V_s = settling velocity of target sediment (see **Table 8**) (typically 0.011m/s)

Q/A = applied flow rate divided by basin surface area (m³/s/m²)

n = turbulence or short-circuiting parameter

d_e = μ extended detention depth (m) above permanent pool level

d_p = depth (m) of the permanent pool

d* = depth below the permanent pool level that is sufficient to retain the target sediment (m) – adopt 1.0 m or d_p whichever is lower.

The concept design stage will generally guide the selection of the fraction of target sediment removed (R) and permanent pool depth (d_p) depending on water quality objectives and the nature of local soils/ sediments. **Table 8** lists the typical settling velocities (v_s) of sediments under 'ideal conditions' (velocity in standing water).

to capture the design sediment particles.

RECOMMENDED APPROACH

The required area (A) of a sedimentation basin should be defined through the use of the following expression (modified version of Fair and Geyer (1954)):

Equation 2 is applied with n being a turbulence parameter that is related to hydraulic efficiency (λ). Figure 17 provides guidance on estimating a hydraulic efficiency (λ) value that is then used to calculate an appropriate n value (according to the configuration of the basin). The shape of a basin has a large impact on the effectiveness of the basin to retain sediments. Generally, a length to width ratio of at least 3 to 1 should be achieved. In addition, the location of the inlet and outlet, flow 'spreaders' and internal baffles impact the hydraulic efficiency of the basin for stormwater treatment as the range of values in Figure

17 demonstrates. Figure 17 provides some guidance on what is considered to be good basin design, with the higher values (of λ) representing basins with good sediment retention properties. Sedimentation basins should be designed to have a λ value of not less than 0.5. If the basin configuration yields a lower value, modification to the basin configuration should be explored to increase the λ value (e.g. inclusion of baffles, islands or flow spreaders). A value of n is estimated using the following relationship:

EQUATION 2
$$\lambda = 1 - 1/n; \text{ so } n = \frac{1}{1-\lambda}$$

λ is estimated from the configuration of the basin according to Figure 17.

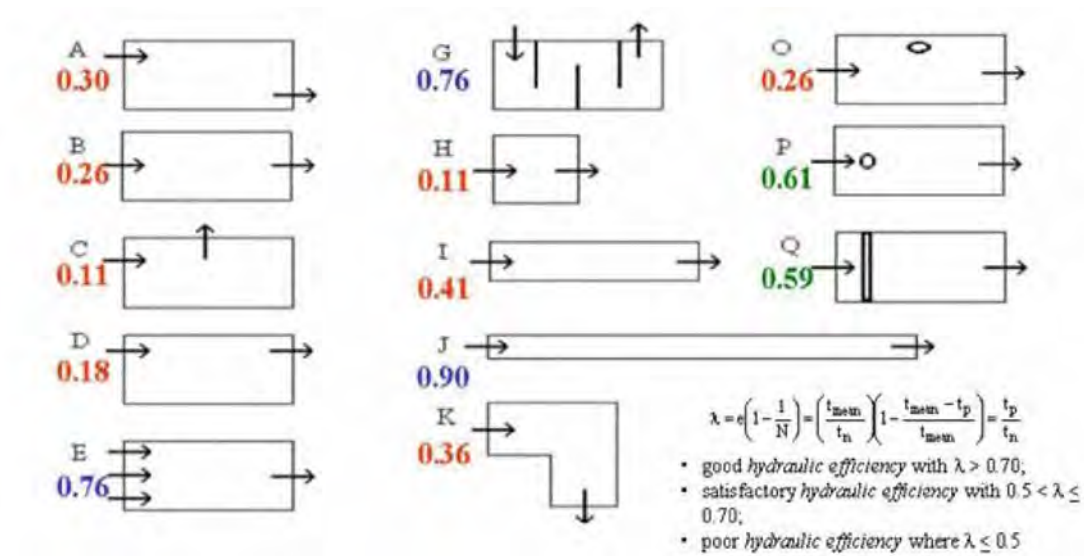

FIGURE 17 hydraulic efficiency λ

Hydraulic efficiency ranges from 0 to 1, with 1 representing the best hydrodynamic conditions for stormwater treatment. The o in diagrams O and P represent islands in the waterbody and the double line in diagram Q represents a weir structure to distribute flows evenly (Persson et al. 1999). Good practice in the design of sedimentation basins is to include a permanent pool to reduce flow velocities and provide storage of settled sediment. The presence of a permanent pool reduces flow velocities in the sedimentation basin and thus increases detention times. With the outlet structure being located some distance above the bed of a sedimentation basin, it is also not necessary for sediment particles to settle all the way to the bed of the basin to be effectively retained. It is envisaged that sediments need only settle to an effective depth (d^*) which is less than the depth to the bed of the sedimentation basin. This depth is considered to be approximately 1.0 m below the permanent pool level.

3.4.3 DEPTH AND STORAGE VOLUME

PERFORMANCE OUTCOMES

Sediment basins must contain sufficient storage volume to store sediment within the cleanout frequency agreed with the ultimate asset manager.

RECOMMENDED APPROACH

A further consideration in the design of a sedimentation basin is the provision of adequate storage for settled sediment to prevent the need for frequent desilting. The ideal depth for the sediment basin is between 1.5m and 2.0m deep. As a guide, a desirable frequency of basin desilting is once every five years (triggered when sediment accumulates to half the basin depth). To ensure this storage zone is appropriate the following must be met:

Sedimentation Basin Storage Volume (V_s) > Volume of accumulated sediment over 5 yrs ($V_{s;5yr}$)

The sedimentation basin storage volume (V_s) is defined as the storage available in the bottom half of the sedimentation basin permanent pool depth. V_s can be calculated using a product of the sedimentation basin area (A_b) and half the permanent pool depth ($0.5 \times d_p$) and appropriate consideration of the internal batters. The volume of accumulated sediments over 5 years ($V_{s;5yr}$) is established by gaining an understanding of the sediment loads entering the sedimentation basin and applying the fraction of target sediment removed (R):

EQUATION 3
$$V_s = A_c \cdot R \cdot L_o \cdot F_c$$

Where V_s = volume of sediment storage required (m^3)

A_c = contributing catchment area (ha)

R = capture efficiency (%), estimated from Equation 1

L_o = sediment loading rate ($m_3/ha/year$)

F_c = desired cleanout frequency (years)

A catchment loading rate (L_o) of $0.6 m_3/ha/year$ for developed catchments can be used to estimate the sediment loads entering the basin.



FIGURE 18 Sediment basin overflow pit

Photo by Brad Dalrymple – BMT WBM

3.4.4 HYDRAULIC CONNECTION TO MACROPHYTE ZONE

3.4.4.1 OVERFLOW PIT

An overflow flow pit, located in the sediment basin provides a means to transfer water in a controlled way from the sediment basin to the macrophyte zone **Figure 18**.

PERFORMANCE OUTCOMES

The design of the hydraulic connection of the sediment basin to the macrophyte zone must deliver a solution that:

- conveys water up to the design flow from the sediment basin to the macrophyte zone
- avoids blockage of pipes
- is accessible by maintenance staff

RECOMMENDED APPROACH

The outlet of a sediment basin can be configured in many ways and is generally dependent on the design flow entering the basin. In most cases, the outlet design of a sediment basin will consist of a 'control' outlet structure and a 'spillway' outlet structure:

- The 'control' outlet can be an overflow pit to pipe or pipe which delivers flows up to the 'design flow' (Section 3.4.1) to the macrophyte zone.

- The 'spillway' outlet structure ensures that flows above the 'design flow' are discharged to a high flow bypass channel or conveyance system.

Assuming the 'control' outlet structure discharging to the treatment system is an overflow pit and pipe, the following criteria apply:

- Ensure that the crest of the overflow pit sets the water level in the sediment basin. It should be at or a maximum of 0,2m above the normal water level in the macrophyte zone.
- The overflow pit is sized to convey the design operational flow (e.g. 1 year ARI). The dimension of an outlet pit is determined by considering two flow conditions: weir and orifice flow (**Equation 4** and **Equation 5** below). Generally, the discharge pipe from the sediment basin (and downstream water levels) will control the maximum flow rate from the basin; it is therefore less critical if the outlet pit is oversized to allow for blockage.
- Provide protection against blockage by flood debris
- It is recommended that the pit is located towards the edge of the sediment basin where it can be accessed for occasional maintenance

Design Note: spill Containment

It is possible to modify the outlet to facilitate spill containment. This may include baffles around the overflow pit. Reverse grade pipes (with no overflow pit) may also be used to trap pollutants that are lighter than water within the sediment basin.

The following equations apply to the design of 'control' outlet devices:

1 Weir flow condition – when free overfall conditions occur over the pit:

EQUATION 4

Where P = perimeter of the outlet pit (m)

B = blockage factor (0.5)

h = depth of water above the crest of the outlet pit (m)

Q_{des} = design discharge (m³/s)

C_w = weir coefficient (1.66)

$$P = \frac{Q_{des}}{B \cdot C_w \cdot h^{3/2}}$$

2 Orifice flow conditions – when the inlet pit is completely submerged (corresponding to conditions associated with larger flood events):

EQUATION 5

Where C_d = orifice discharge coefficient (0.6)

B = blockage factor (0.5)

h = depth of water above the centroid of the orifice (m)

A_o = orifice area (m²)

Q_{des} = design discharge (m³/s)

$$A_o = \frac{Q_{des}}{B \cdot C_d \cdot \sqrt{2 \cdot g \cdot h}}$$

It is important that an outlet pit is prevented from blockage by debris. Design consideration needs to include a grate, preferably dome grate, over the pit in accordance with the local government standards.

3.4.4.2 PIPE CONNECTION FROM SEDIMENT BASIN TO MACROPHYTE ZONE

The pipe connection from the sediment basin overflow pit to the macrophyte zone very often provides the hydraulic control that limits flows passing through to the macrophyte zone and prevents scour from large storm events.

PERFORMANCE OUTCOMES

Pipes must be sized to convey the 'design flow' event from the sediment basin to the macrophyte zone.

RECOMMENDED APPROACH

The pipe that connects the sediment basin to the macrophyte zone must have sufficient capacity to

convey a 1 year ARI flow. Where the obvert of the pipe will be submerged by the macrophyte zones normal water level, the pipe grade is not important. It can be horizontal or slope away from the grated pit to the macrophyte zone.

If the outlet of the connection pipe is submerged, an energy loss equation can be used to estimate the pipe velocity using the following:

EQUATION 6

$$h = \frac{2 \cdot V^2}{2 \cdot g}$$

Where: h = head level driving flow through the pipe (defined as the 'spillway' outlet level minus the normal water level in the macrophyte zone)

V = pipe velocity (m/s)

g = gravity (9.81 m/s²)

Note: the coefficient of 2 in the equation is a conservative estimate of the sum of entry and exit loss coefficients (K_{in} + K_{out}).

The area of pipe required to convey the 'design flow' (1 year ARI) is then calculated by dividing the 'design flow' by the velocity.



FIGURE 19 Sediment basin pipe connection only

Photo: Shaun Leinster - DesignFlow

3.4.4.3 PIPE CONNECTION ONLY (NO PIT)

In some situations, particularly large wetland, it may not be feasible or practical to have an overflow pit. In this case culverts can be used to convey water from the sediment basin to the macrophyte zone without the pit (**Figure 19**).

PERFORMANCE OUTCOMES

Pipes must be sized to convey the design flow event from the sediment basin to the macrophyte zone while ensuring collected sediment is retained in the sediment basin.

RECOMMENDED APPROACH

The pipe that connects the sediment basin to the macrophyte zone must have sufficient capacity to convey a 1 year. Standard culvert calculations should be used to confirm pipe size in accordance with local authorities standard or QUDM. The tailwater level should be set at the normal water level in the macrophyte zone and the headwater is the crest of the high flow bypass weir (i.e. top of extended detention). The invert level of the pipe should be no deeper than 0.3m below the sediment basin water level to avoid resuspending sediment movement of this sediment into the macrophyte zone.

Design Note: Replacing overflow weir with a pit

Where site constraints such as space, steep slopes, unstable soils, or retaining walls limit the use of weirs, an appropriately sized overflow pit and pipe can provide an outlet for major storm events, however, some form of overland flow or spillway will still be required for extreme flood events.

3.4.5 BYPASS/OVERFLOW WEIR

Flows bypass the wetland macrophyte during larger storm events and when the wetland extended detention depth is reached. This is required to protect the wetland from excessive inundation and scour. Bypass occurs out of the sediment basin via the bypass/overflow weir which directs flows to the high flow bypass channel or directly to the receiving drainage system (if the sediment basin is located next to the drainage system).

PERFORMANCE OUTCOMES

The design of high flow bypass overflow weir (or equivalent) must:

- be able to pass the peak major flow with acceptable upstream inundation
- have a low risk of being blocked with debris
- manage velocities to minimise the risk of scour during a peak major flow.

RECOMMENDED APPROACH

A safe and stable route for discharging peak major flows from the sediment basin is required. This is generally achieved by using an overflow weir.

A suitable freeboard is required between the maximum water level above the weir during the peak major flow event and the embankment level (see **Section 3.2.7**). The drop from the crest of the weir to the downstream finished surface level should be as low as possible to minimise scour and reduce costs. Weirs should be keyed into embankments to minimise scour.

Overflow weirs are generally large concrete and rock structures. Weirs should be configured in accordance with local standards such as the IPWEA Standard Drawings. They should be positioned away from highly visible areas and masked with planting. Appropriate scour protection, and where required energy dissipation, must be provided around all weirs. Rock protection or rock mattresses on the downstream side of weirs should be designed in accordance with local authority requirements.

The required length of the 'spillway' outlet weir can be computed using the weir flow equation (**Equation 4**), using blockage factor equal to 1.0) and the 'above design flow' (**Section 3.4.1**). **Figure 20** shows examples of 'spillway' weir outlets.



FIGURE 20 Photo spillway weir outlet

Photo by Shaun Leinster

3.4.6 INLET ENERGY DISSIPATION AND SCOUR PROTECTION

Wetland inlets may require energy dissipation and scour protection to avoid damage to littoral edge vegetation from inflows, and to minimise the re-suspension of coarse sediment collected near the inlet.

PERFORMANCE OUTCOMES

Energy dissipation and scour protection must:

- prevent littoral edge vegetation from scouring during a major storm event
- minimise re-suspension of coarse sediment collected near the inlet.

RECOMMENDED APPROACH

Inflows to sediment basins will require some form of energy dissipation or scour protection to ensure that concentrated flow paths do not damage or destabilize vegetated batters.

For sediment basins, scour protection is typically limited to a rock apron at the headwall. Energy will dissipate as flows enter the deep water and velocities decrease. Incoming pipe inverts should be set as close as possible to the normal standing water level of the sediment basin to limit turbulence and re-suspension of sediment, and to maximise energy dissipation. Rock aprons and energy dissipaters should be designed in accordance with local authority requirements or QUDM.



FIGURE 21 Constructed Wetland Bypass Weir and Channel Configurations

Photo: Shaun Leinster

3.4.7 HIGH FLOW BYPASS CHANNEL

Constructed wetlands can generally only handle a proportion of the total flow and volume of water from a catchment. The high flow bypass channel (combined with the bypass/overflow weir ensures that the wetland is protected from scour and excessive inundation).

PERFORMANCE OUTCOMES

Design of the high flow bypass must:

- Safely convey the above design flow event around the macrophyte zone
- Minimise scour and erosion of channel
- Enhance public safety

RECOMMENDED APPROACH

The bypass channel accepts 'above design flow' from the sediment basin zone of the wetland via the bypass weir and conveys these flows downstream around the macrophyte zone of the wetland. The bypass channel should be designed using standard methods (i.e. Manning's Equation) to convey the 'above design flow' (Section 3.4.1) and to avoid bed and bank erosion. Typically, a turf finish will provide appropriate protection for most bypass channel applications (but velocities need to be checked). **Figure 21** shows typical high flow bypass channel configurations.

For sections of the high flow bypass with pedestrian access a depth x velocity (d.v) assessment should be undertaken in accordance with QUDM (DEWS 2013).

3.5 Macrophyte Zone Design



FIGURE 22 Constructed Wetland Macrophyte Zone

Photos: Shaun Leinster

The macrophyte zone is a densely planted basin with shallow ponded water and typically has deep open water pools at the inlet and outlet (Figure 22). The macrophyte zone is where the majority of fine sedimentation and nutrient uptake occurs. Detailed design of the macrophyte zone entails design of:

- Area
 - Shape
 - Bathymetry
 - Batters and edge design
 - Outlet
- The layout of the macrophyte zone needs to be configured to balance the contact time that water flowing through the system has with vegetation, maximising the volume of water captured by the system (hydrologic effectiveness) and ensuring that healthy vegetation is sustained. Design considerations include:
- The preferred extended detention depth is 0.5 m. Deeper extended detention depths are not recommended.
- The bathymetry of the macrophyte zone should be designed to ensure 80% coverage of vegetation (80% < 0.4m depth) promote a sequence of marsh and deep marsh zones in addition to small open water zones.
 - The macrophyte zone is required to retain water permanently and therefore the base must be of suitable material to retain water (eg. clay). If in-situ soils are unsuitable for water retention, a clay liner (e.g. compacted 300 mm thick) or synthetic liner must be used to ensure there will be permanent water for vegetation and habitat.
 - The bathymetry of the macrophyte zone should be designed so that all marsh zones are connected to a deeper open water zone to allow mosquito predators to seek refuge in the deeper open water zones during periods of extended dry weather.
 - Particular attention should be given to the placement of the inlet and outlet structures, the length to width ratio of the macrophyte zone (length > 4 x average width) and flow control features to promote a plug flow and high hydraulic efficiency within the macrophyte zone.
 - Provision to drain the macrophyte zone for water level management during the plant establishment phase should also be considered.
 - The macrophyte zone outlet structure needs to be designed to provide a notional detention time (greater than 48 hours 90% of the time) for a wide range of flow depths. The outlet structure should also include measures to exclude debris to prevent clogging.

Design Note: Temporary flow diversion during establishment

Provision should be made to divert water around the macrophyte zone during the plant establishment phase. This can be achieved by blocking the overflow pit connection to the macrophyte zone **Figure 23**. Any flows into the sediment basin will then pass over the spillway weir and into the high flow bypass.



FIGURE 23 Photo Overflow pit blockage and flow diversion

Photo: Shaun Leinster

3.5.1 TREATMENT AREA

Constructed wetlands remove pollutants as stormwater flows past and is in contact with vegetation. The area at normal water level (treatment area) is therefore an important design criteria.

PERFORMANCE OUTCOMES

The treatment area must be sufficient to achieve the constructed wetland's design objectives

RECOMMENDED APPROACH

The required treatment area should be confirmed using catchment information collated in Section 3.1. One of the following sizing options should be used:

- **Confirming concept design size.** The treatment area should have been determined during the concept design phase (e.g. using MUSIC software or the *Deemed to Comply Solutions – Stormwater Quality Management* (Water by

Design)). If the catchment and wetland system's properties (e.g. catchment area and land use, extended detention depth) have not changed since conceptual design, then the treatment size should remain valid.

- **MUSIC modelling.** Where catchment or constructed wetland properties have changed since conceptual design, MUSIC software can be used to confirm the treatment area needed to achieve relevant stormwater management objectives.
- **Maximising size (retrofit).** Where the available space for a constructed wetland is constrained (i.e. less than required to meet relevant stormwater objectives), the design team should investigate options to maximise the treatment area whilst balancing other opportunities and constraints. This requires consideration of surroundings and an iterative approach to designing the constructed wetland's layout and levels.

Design Note: Timing of development within the catchment

During the design process, it is important to consider the timing of development within a constructed wetlands' catchment. Refer to the **Construction and Establishment Guidelines: Swales, Bioretention Systems and Wetlands** (Water by Design) to identify construction staging options and any methods for ensuring wetland systems are resilient while the catchment is being developed. Key considerations include:

- location of inflow and outflow points
- protection of macrophyte zone from high sediment loads
- management of overland flow paths into or around the system
- use of the system (without plants installed) as a sediment basin during construction, this will mitigate sediment impacts on waterways
- delivery of large systems whose catchment will have building and construction activity occurring over several years or more.

If the implications of a constructed wetland location, construction technique and initial sediment load protection and management options are not considered during the design, major constraints can occur during the construction phase. Poorly designed, poorly constructed or damaged wetland systems may not be accepted by a local authority at the post-development asset handover stage.

3.5.2 SHAPE

PERFORMANCE OUTCOMES

Design of the macrophyte zone must:

- Optimise the hydraulic efficiency
- Avoid dead pockets of water

RECOMMENDED APPROACH

To optimise wetland performance, it is important to avoid short circuit flow paths and poorly mixed regions within the macrophyte zone. This requires the length of the macrophyte zone to be greater than 4 times the average width of the macrophyte zone. Length to width ratios less than this can lead to poor hydrodynamic conditions and reduced water quality treatment performance.

Persson et al. (1999) used the term hydraulic efficiency (λ) to define the expected hydrodynamic characteristics for a range of configurations of

stormwater detention systems (**Figure 17**). Engineers Australia (2006) recommend that constructed wetland systems should not have a hydraulic efficiency (λ) less than 0.5 and preferably should be greater than 0.7.

Ideally, the width of the macrophyte zone should be kept consistent to avoid "dead" pockets of water. Curved edges are also recommended to avoid "dead pockets". There should be no islands in the macrophyte zone.

Sharp bends should be avoided where possible as they are likely to promote some short circuiting of flows. The risk of short circuiting at bends can be minimised by placing a deep zone of open water at the bend.

The macrophyte zone can be split between multiple cells to accommodate constraints such as pedestrian paths and steeper sites with level constraints. Using multiple cells is likely to increase the total wetland footprint.

Design Note: coarse sediment removal areas

Space for a sediment basin should be included in the overall constructed wetland's layout. The area required for these elements is in addition to the macrophyte zone treatment area.

3.5.3 BATHYMETRY (OR DEPTH)

PERFORMANCE OUTCOMES

Design of the macrophyte zone must:

- Limit short circuiting
- Provide optimal depths for plant growth and 80% plant cover of the macrophyte zone

RECOMMENDED APPROACH

Wetland bathymetry and vegetation influence the distribution of flows through a wetland, which has implications for the level of treatment achieved. The bathymetry of the macrophyte zone should be designed to:

- ensure a greater than 80% coverage of emergent macrophytes
- ensure that 80% or more of the macrophyte zone is 0.4 m or shallower at normal water level (depths range from 0.4 to 0.1 m below NWL for 80% of the macrophyte zone)
- promote a sequence of marsh zones including, shallow marsh and deep marsh zones in addition to open water zones.
- marsh zones should be connected to an open water zone that is deep enough to retain sufficient water throughout the dry season to allow mosquito predators to seek refuge.

Ephemeral marsh zones within the longitudinal flow path (i.e. not the batters) are considered optional.

Ephemeral zones have a higher risk of weed infestation. Therefore, the preference is to avoid areas of ephemeral marsh. Where an ephemeral zone is to be incorporated into a wetland consideration needs to be given to minimising weeds through plant selection (i.e. consider use of jute matting, or shrubs and trees to manage weeds in this zone).

Planting zones should be arranged in bands running across (i.e. perpendicular to) the flow path as shown in **Figure 24** and **Figure 25**. The appropriate bathymetry, coupled with uniform plant establishment, ensures the macrophyte zone cross section has uniform hydraulic conveyance, thus reducing the risk of short circuiting.

The base of open water zones should be between 1.2 and 1.5 m below the normal level to avoid colonisation by emergent macrophytes and allow for colonisation for submerged macrophytes. Deep open water zones should be located where submerged wetland inflow and outflow pipes/culverts will be used. Open water is often a desirable aesthetic feature of wetlands and consideration should be given to locating open water adjacent to wetland viewing locations (e.g. decks or roads).

The longitudinal grade through the wetland should generally be at least 1:150. Where milder slopes are used it is more difficult to ensure that pockets of water (i.e. mosquito breeding habitat) are not left behind as the surface is exposed during extended dry periods. Where slopes milder than 1:150 are used, it is recommended that they are at least 0.25 m below normal water level, where they are unlikely to be regularly exposed.

Figure 24: Example Bathymetry of a Constructed Wetland System

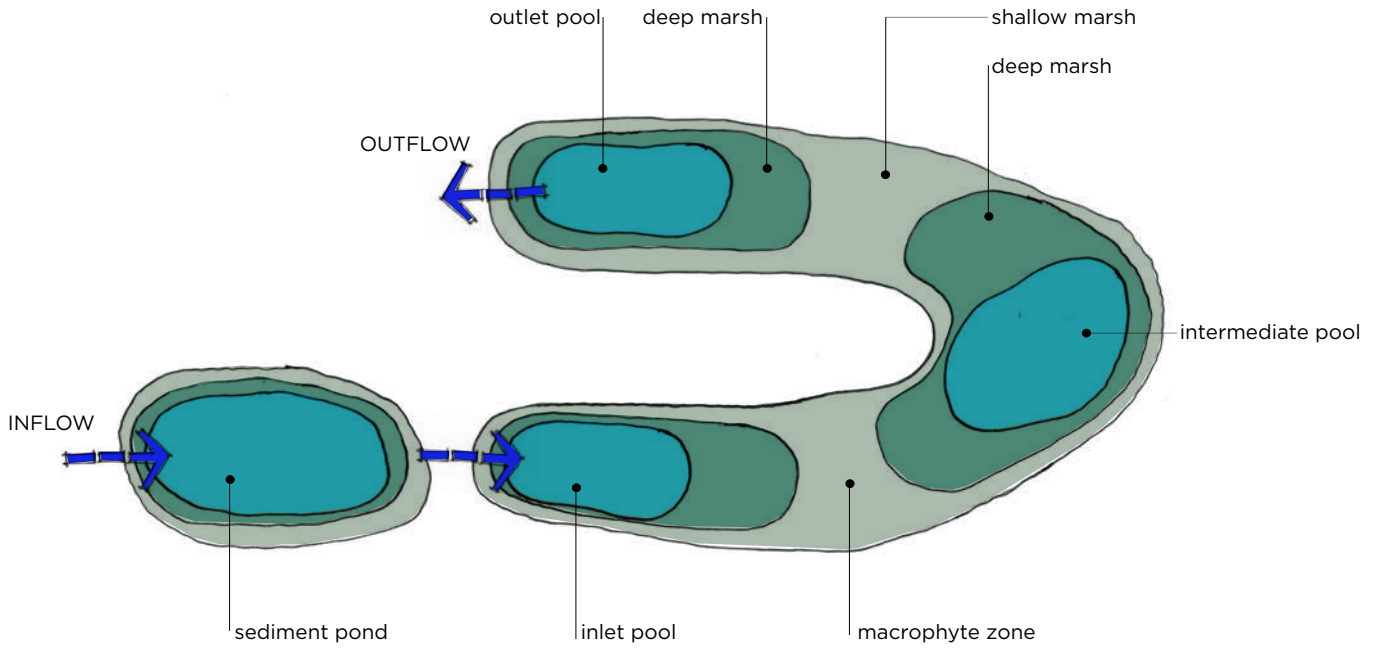
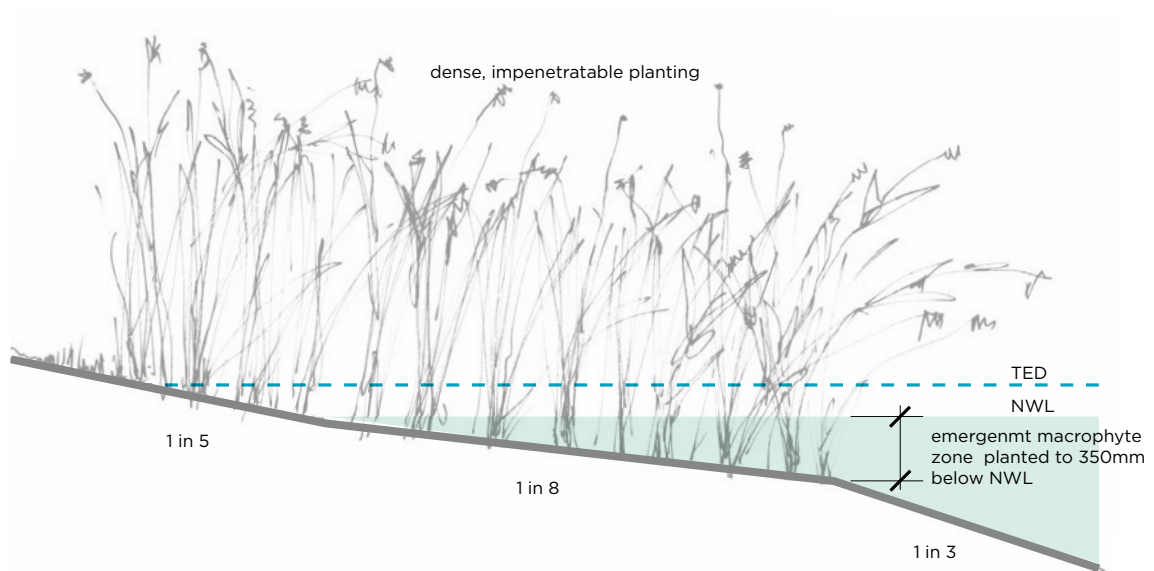

FIGURE 25 Macrophyte Zone Planting and Bathymetry

Photo: Glenn Browning - AECOM





SHALLOW MACROPHYTE ZONES

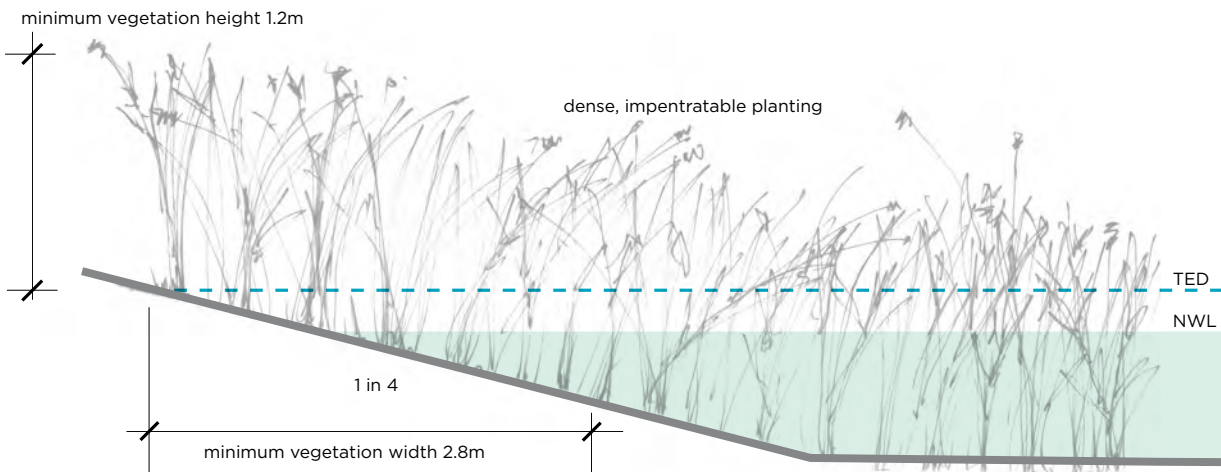

FIGURE 26: Example of Edge Design to a Constructed Wetland System

3.5.4 BATTERS

PERFORMANCE OUTCOMES

The design must show how the constructed wetland batters have:

- minimised safety risks and are stable
- minimised maintenance
- been integrated to minimise unacceptable visual impacts
- enhance public safety

RECOMMENDED APPROACH

The batter slopes on approaches and immediately under the permanent water level have to be configured with consideration of public safety (refer **Figure 26** and **Figure 27**). It is recommended that a gentle slope to the water edge and extending below the water line be adopted before the batter slope steepens into deeper areas.



FIGURE 27 Safety Bench during plant installation

Photo Paul Dubowski – BMT WBM

The safety requirements for individual wetlands will vary from site to site and requires careful consideration.

All wetland edges must have:

- For sediment basins and deep pools (depth > 0.4m): vegetated approach batters no steeper than 1:5, a 2.8 metre wide vegetated safety bench at 1:8 between NWL and 350 mm below NWL and a maximum 1:3 slope beyond 350 mm below NWL.
- For shallow macrophyte areas (depth ≤ 0.4m): Batters no steeper than 1:4 between TED and 350 mm below NWL with dense impenetrable planting that is a minimum of 2.8 metres wide and 1.2 metres high.

For batters in excess of this refer to **Section 2.2.5** for guidance on public safety and risk analysis.

Batters and embankments should be densely vegetated and mulched to manage weed ingress. Groundcover coverage of 90% is recommended for all batters, which requires a planting density of around six plants per square metre. Lower planting densities may be applicable for certain plant species subject to local authority approval. Lateral flows down batters that are 1 in 3 or steeper should be avoided by creating designated inflow points with adequate erosion protection (swales/rock lined channel). Planting of trees on key bunds is not advised due to the potential of bund failure if the tree dies.



FIGURE 28 Photo Well designed wetland walls

Photo: Glenn Browning – Water by Design

3.5.5 WALLS

PERFORMANCE OUTCOMES

The design must show how the walls around constructed wetlands have:

- minimised safety risks and are stable
- not created unacceptable visual impacts
- allowed the system to be easily constructed and maintained.

RECOMMENDED APPROACH

Constructed wetlands should be designed without walls, where possible, because they present a potential safety hazard. However, walls may be acceptable in steep terrain, to preserve existing vegetation, or for aesthetic reasons. Local authorities should be consulted when walls are being proposed

for constructed wetlands. Specialist geotechnical advice should be sought for designing retaining walls.

Well-designed walls can provide interesting landscape finishes adjacent to a constructed wetland (**Figure 28**). However, badly designed and high walls result in poor landscape outcomes, maintenance difficulties and public safety problems.

Where vertical drops are greater than 800 mm, it is recommended that more than one wall (each ≤ 800 mm high) are used. The walls should be separated by a vegetated strip that is at least 1.5 m wide and planted with trees. Where a wall is only used for part of the system perimeter, batters in accordance with **Section 3.5.4** should be used for the rest of the perimeter of the constructed wetlands.

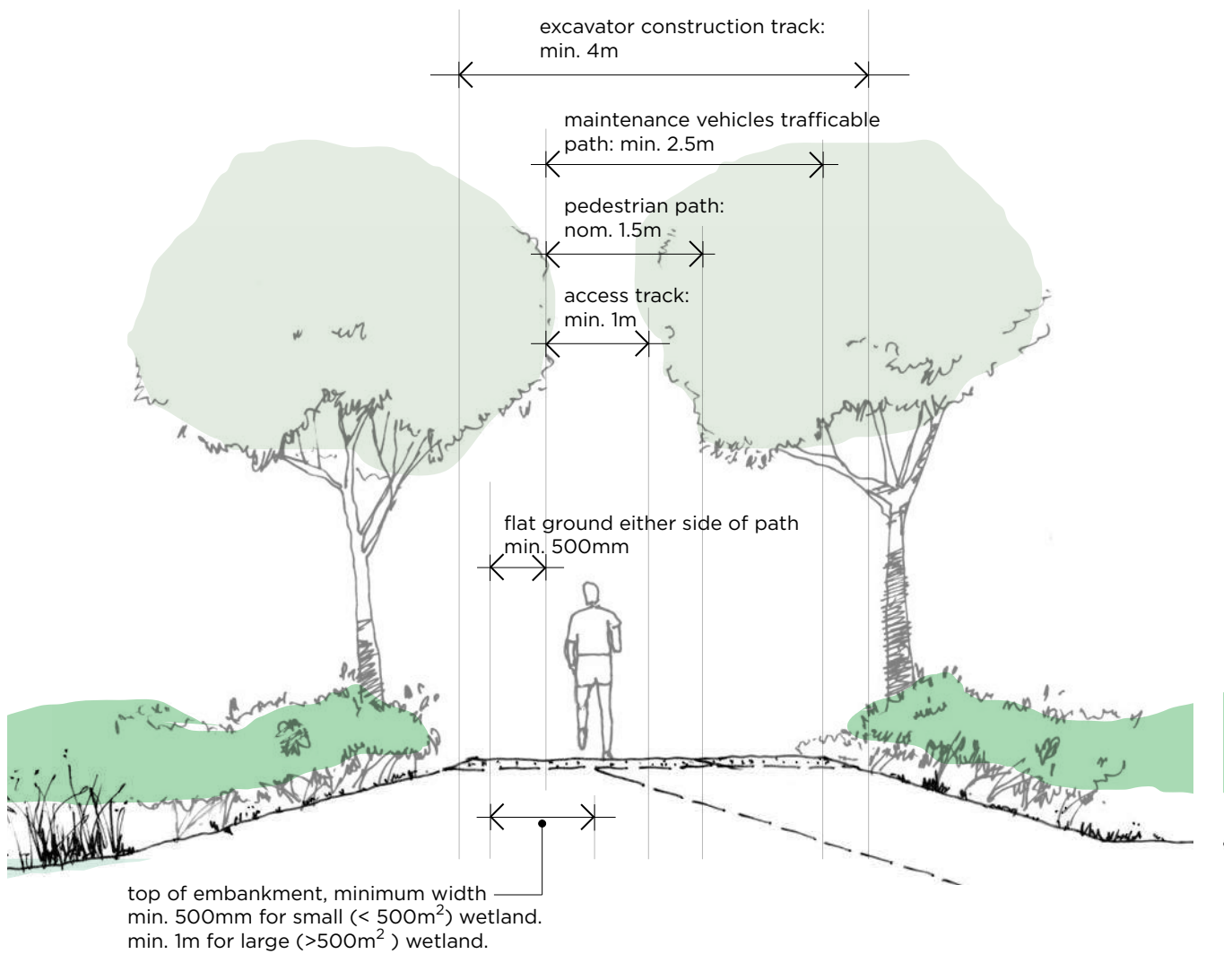

FIGURE 29 Embankment width requirements

3.5.6 EMBANKMENTS

The function of embankments are to contain water within the constructed wetlands and provide access for maintenance.

PERFORMANCE OUTCOMES

The design must show how the constructed wetland embankments have:

- Contain water in the wetland during and following storm events
- minimised safety risks and are stable
- minimised maintenance

- been integrated to minimise unacceptable visual impacts
- provided for construction and maintenance of the system.

RECOMMENDED APPROACH

Constructed wetland embankments must be designed to serve the multiple roles of retaining design stormwater flows, providing access for construction and maintenance and providing pedestrian access. The recommended approach for designing embankments around constructed wetlands is shown in **Figure 29**.

3.5.7 MACROPHYTE ZONE OUTLET

The outlet of the macrophyte zone is a key hydraulic structure in a constructed wetland. It controls water flow, volumes and levels and provides a way for draining the wetland form maintenance.

PERFORMANCE OUTCOMES

The design must show how the provided macrophyte zone outlet:

- Controls water level and flows in the macrophyte zone to achieve the design detention time (> 48hrs more than 90% of the time),
- Minimises the risk of scour
- Allows the wetland permanent pool to be drained for maintenance.

RECOMMENDED APPROACH

The outlet to the macrophyte zone should be sized with consideration of:

- Residence time - The residence time for constructed wetlands in Queensland should be 48 hours for more than 90% of the time.
- Extended detention – The extended detention depth must be equal to or less than 0.5 m.
- In situations where elevated water levels are likely refer to **Section 2.2.3**.

For large wetlands (greater than 5,000 m²), it is recommended that a cumulative frequency of residence times is generated (e.g. using a wetland's flux file from MUSIC). A continuous simulation at a timestep of no more than 1 hour should be used for the analysis. Where an outlet configuration other than a single, horizontal orifice is being proposed, a user defined storage/discharge relationship must be entered in MUSIC. An allowance for the varying storage volume should be made. Reference should be made to Part D of the Melbourne Water's Constructed Wetland Design Manual for further information regarding design of outlets for large basins. <https://www.melbournewater.com.au/planning-and-building/standards-and-specifications/design-wsud/pages/constructed-wetlands-design-manual.aspx>

For small wetlands (up to 5,000 m²), a simplified steady state estimate of residence time can be made by calculating the residence time for a range of constant water levels. When using this approach, the residence time should not be less than 48 hours for any of these conditions. Hydraulic calculations (e.g. using the orifice and/or weir equation) can be used to estimate the outlet flow rate for a given water level. The residence time is calculated by dividing the storage volume at that water level (extended detention plus up to 50% of permanent pool) by the discharge rate. The steady state residence/detention time should be calculated at the top of extended detention plus at least three evenly space intermediate water levels.

3.5.7.1 RISER OUTLET – SIZE AND LOCATION OF ORIFICES

The riser outlet is designed to provide a uniform residence time in the macrophyte zone over the full range of the extended detention depths. The target

maximum discharge ($Q_{\max \text{ riser}}$) may be computed as the ratio of the volume of the extended detention to the notional detention time as follows:

EQUATION 7

$$Q_{\max \text{ riser}} = \frac{\text{extended detention storage volume (m}^3\text{)}}{\text{notional detention time (s)}}$$

The placement of orifices along the riser and determining their appropriate diameters is an iterative process. The orifice equation (**Equation 8**) is applied over discrete depths along the length of the riser starting at the permanent pool level and extending up

to the riser maximum extended detention depth. This can be performed with a spreadsheet as illustrated in the worked example in **Section 5.1.5**.

EQUATION 8

$$A_o = \frac{Q}{C_d \sqrt{2 \cdot g \cdot h}}$$

Where	C_d	=	orifice discharge coefficient (0.6)
	h	=	depth of water above the centroid of the orifice (m)
	A_o	=	orifice area (m ²)
	Q	=	required flow rate to achieve notional detention time (m ³ /s) at the given h
	g	=	9.79 m/s ²

The pit is connected to the permanent pool of the macrophyte zone via a submerged pipe culvert. The connection should be adequately sized such that there is minimal water level difference between the water within the pit and the water level in the macrophyte zone. With the water entering into the outlet pit being drawn from below the permanent pool level (i.e. pipe invert a minimum 0.3 m below permanent pool level), floating debris is generally prevented from entering the outlet pit, while heavier debris would normally settle onto the bottom of the wetland.

The riser pit must be located in the embankment surrounding the wetland macrophyte to allow maintenance access. Concrete collars or leakage cut-off walls must be installed on all pipe connection through the bund to avoid leakage.

The riser pipe should be securely mounted upright on a socketed and flanged tee with the top of the pipe left open to allow overtopping of waters if any of the riser orifices become blocked. Riser orifices should be designed appropriately to minimise blockages. **Figure 30** and **Figure 31** shows one possible configuration for a riser outlet pit.

A riser within the pit can also be configured with a weir plate by drilling holes through the plate (refer **Figure 32**). An advantage of using a weir plate is that it provides an ability to drain the wetland simply by removing the weir plate entirely. Additionally, shorter weir plates may also be used during the vegetation establishment phase, thus providing more flexibility for water level manipulation.

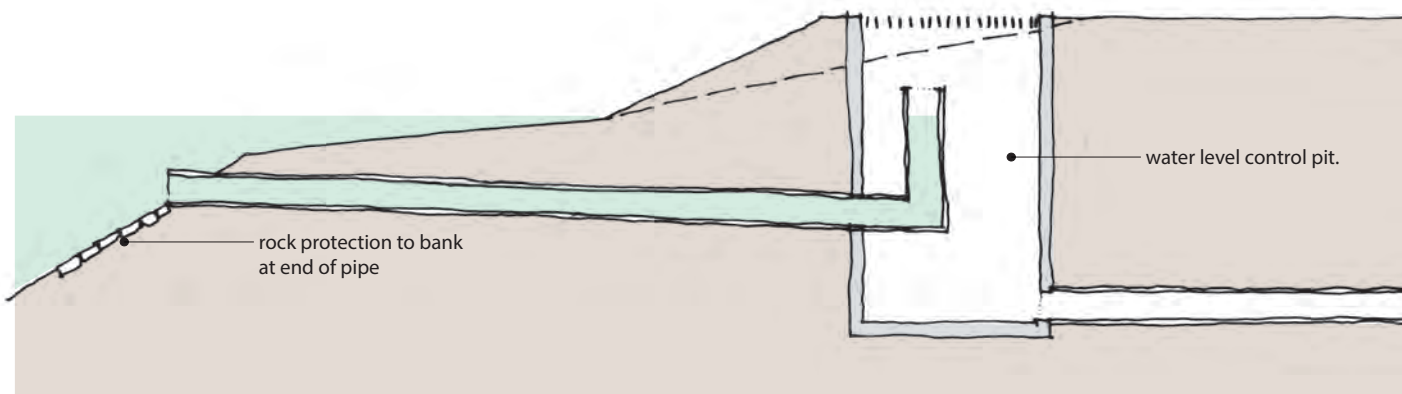

FIGURE 30: Typical Macrophyte Zone Outlet Arrangement



FIGURE 31 Photo outlet riser
Photo: Shaun Leinster - DesignFlow



FIGURE 32 Plate riser
Photo: Jason Sonneman - DesignFlow

Design Note: Fish friendly outlets

For large wetlands connected to waterways, consideration may be given to providing fish passage through the outlet riser. This can be achieved by using a slot weir (Figure 33) (with no air space to receiving water level) and fish ladders.



FIGURE 33 Slot weir outlet

Photo: Shaun Leinster - DesignFlow



FIGURE 34 Wetland outlets to be avoided

Control outlets or riser outlets located within the macrophyte zone with debris guards must be avoided (refer Figure 34). These outlets are difficult to access for maintenance and are likely to block with floating inorganic and organic litter resulting in the raising of normal water levels and the subsequent drowning of wetland plants.

Design Note: Macrophyte Zone Weir Outlets

In situations where the sediment basin extended detention is higher than the macrophyte zone extended detention there will need to be an overflow weir on the macrophyte zone.

Where the macrophyte zone and sediment basin have a common top of extended detention, a macrophyte zone overflow may be used to minimise maximum water level and therefore the required height of embankments around the perimeter of the macrophyte zone.

A grated pit and pipe can also be used (particularly in small systems and/or where overflows are to be directed to an underground drainage system).

3.5.7.2 MAINTENANCE DRAINS

To allow access for maintenance, the wetland should have appropriate allowance for draining. Ideally a maintenance drainage pipe should be provided that connects the low points in the macrophyte zone bathymetry to the macrophyte zone outlet. A valve is provided on the maintenance drainage pipe (typically located in the outlet pit or a separate pit) which can be operated manually. The maintenance drainage pipe should be sized to draw down the permanent pool within 12 hours (i.e. overnight). If a weir plate is used as a riser outlet, provision should be made to remove the weir plate and allow drainage for maintenance. Alternatively the macrophyte zones can be pumped dry should the need arise.

3.5.7.3 OUTLET PIPE

PERFORMANCE OUTCOMES

The outlet pipe must convey the wetland discharge to the receiving drainage system taking into account tailwater conditions.

RECOMMENDED APPROACH

The discharge pipe of the wetland conveys the outflow of the macrophyte zone to the receiving waters (or existing drainage infrastructure). The

conveyance capacity of the discharge pipe is to be sized to match the higher of the two discharges (i.e. maximum discharge from the riser or the maximum discharge from the maintenance drain).

Outlet pipes should be designed in accordance with local authority standard drainage requirements. Outlet pipes need to convey the relevant design flow from the pit considering tailwater conditions. All pipe outlets through embankments should be appropriately backfilled, compacted, and have an anti-seepage collar, cut-off walls, or filter collars to prevent seepage paths developing along the pipe. Failure to appropriately account for seepage can result in structural issues for embankment walls or dewatering of the wetland.

Scour protection is required at pipe outfalls and along overland flow paths in line with local authority design standards or QUDM.

3.5.7.4 CONNECTION TO WATERWAYS

PERFORMANCE OUTCOMES

The connection of the constructed wetland to the receiving drainage system must prevent scour during peak major flows.

RECOMMENDED APPROACH

When discharging wetland outflows to waterways:

- pipes and weirs should be angled downstream
- pipes or drains should be free draining (i.e. refer Section 3.2.2).

Scour protection (e.g. rock drop structure) should be used to transition from a wetland outlet to a waterway. Where a transition includes a vertical drop of greater than 400 mm, major grade control and scour protection is recommended. For guidance on outlet design, energy dissipation, and stabilisation refer to local design guidelines and standards such as QUDM (DEWS, 2013).

3.5.8 RESUSPENSION PROTECTION

PERFORMANCE OUTCOMES

Velocities through the macrophyte zone should be managed to avoid sediment resuspension.

EQUATION 9

$$\frac{Q_{\max \text{ riser}}}{A_{\text{section}}} < 0.1 \text{ m/s}$$

Where

$Q_{\max \text{ riser}}$ = target maximum discharge (defined in **Equation 7**) (m^3/s)

A_{section} = wetland cross sectional area at narrowest point*, measured from top of extended detention (m^2)

* minimum wetland cross-section is used when undertaking this velocity check

The velocity through the wetland should be less than 0.5 m/s for flows that will pass through macrophyte zone on average once every five years (i.e. maximum flow that will be pushed through connection from sediment basin in 5 year ARI event). Where a wetland is located in the base of a retarding basin, velocities that will occur as the basin fills should be checked. This can be done using a detailed hydraulic model or using the simplified method described below.

RECOMMENDED APPROACH

The principal pathway for biological uptake of soluble nutrients in wetlands is through biofilms (periphyton) attached to the surface of the macrophyte vegetation. The biofilms, being mostly algae and bacteria, are susceptible to wash out under high flow conditions. Further, wetland surveys indicate that up to 90 % of the total nutrients are stored in the sediments, therefore, the key to effective retention of pollutants is to manage high velocity flows that could potentially resuspend and remobilise these stored pollutants.

A velocity check is to be conducted for design conditions, when the wetland water level is at the top of the extended detention level and the riser is operating at design capacity, to ensure velocities are less than 0.1 m/s through all zones of the wetland. The following condition must be met:

The flow velocity in a wetland will be highest at the location with the smallest cross sectional area. The average velocity at this point should be calculated by dividing the flow rate by the cross sectional flow area.

3.6 Maintenance access

3.6.1 SITE ACCESS

PERFORMANCE OUTCOMES

A suitable point to access the wetland location must be provided for maintenance.

RECOMMENDED APPROACH

Formal access to the wetland is required for heavy machinery and vehicles such as excavators, bobcats, trucks, tippers or utilities for sediment basin cleanout and general maintenance activities. Local authorities should be consulted to confirm their maintenance access requirements as part of the design process.

The design of the wetland site access will be dictated by the large machinery requirements for maintenance. This will typically be by excavator, tipper or sucker truck required for the sediment basin maintenance. The site access track must extend from an adjacent road or carpark and preferably be located away from high-use pedestrian areas. Consideration should be given to preventing public vehicle access to maintenance tracks by using lockable gates or bollards.

The site access requirements must be confirmed with the local authority and should meet the following requirements:

- At the road or parking edge, have a heavy industrial crossover to Council standard (typically 200mm thick double reinforced concrete)
- Beyond the crossover, be at least 3.5 m wide to the sediment basin and reinforced concrete to take up to 40 tonne vehicle. Provide suitable parking away from pedestrian pathways for tipper and/or sucker truck.

3.6.2 SEDIMENT BASIN ACCESS

PERFORMANCE OUTCOMES

Access to the sediment basin must be provided to enable sediment cleanout and regular maintenance activities

RECOMMENDED APPROACH

Maintenance access to the sediment basin is required to enable heavy machinery and vehicles such as excavators, bobcats, trucks, tippers or utilities for sediment cleanout. This requires:

- Access ramp down into the sediment basin for heavy vehicles
- Concrete base to the sediment basin to allow easy cleaning
- Parking area for heavy vehicles
- Dewatering area for excavated silt



FIGURE 35 Site access and ramp to sediment basin

Photo by Shaun Leinster - DesignFlow

3.6.2.1 ACCESS RAMP

Maintenance access ramps are required on all sediment basins. The maintenance access ramp into a sediment basin should:

- Extend to the concrete base (refer **Section 3.6.2.2**) or be located along 40% of the edge of the sediment basin just above to allow cleaning from the side.
- Extend all the way up the batter to intersect with the site access (refer **Section 3.6.1**) and parking area (refer **Section 3.6.2.3**)
- Be at least 3m wide (potentially wider depending on local government requirements)
- Have a minimum slope of 1:10 and maximum slope of 1:4

- Be capable of supporting a 22 tonne excavator (consult with local authority regarding loading requirement)
- Be constructed of reinforced concrete to the required loading above
- Have a barrier to prevent unauthorised vehicle access (e.g. gate, bollard and/or fence) Figure 35.

3.6.2.2 BASE

The base of the sediment basin base must have a concrete base to allow for easy cleaning. The concrete must extend up the batter 0.5m. Reinforced concrete capable for supporting a 22 tonne excavator should be used (consult with local authority regarding loading requirement as part of design).



FIGURE 36 Dewatering area

Photo by Andrew Cook - DesignFlow

3.6.2.3 PARKING AREA

A concrete parking area with appropriate space for loading and unloading machinery and must be included at the interface with the site access and access ramp to the sediment basin. The design and loading must be the same as the site access (i.e. reinforced concrete to support 40 tonne vehicles).

3.6.2.4 DEWATERING AREA

A suitable dewatering area for the removed sediments should be provided adjacent to the sediment basin (Figure 36). The dewatering area should be approximately 25% of the sediment basin area (at NWL) and drain towards the basin.

The sediment dewatering area should:

- be accessible from the access ramp and parking area,
- have a length to width ratio no narrower than 10:1,
- be able to contain all sediment removed from the sediment accumulation volume spread out at 500 mm depth
- be located within 25 m of the sediment basin (or as close as possible)
- be located at least 15 m from residential areas and public access areas and consider potential odour and visual issues for local residents
- address public safety and potential impacts on public access to open space areas,



FIGURE 37 Maintenance Track – Reinforced turf

Photo by Paul Dubowski

TABLE 9 WETLAND MACROPHYTE ZONE MAINTENANCE REQUIREMENTS

WETLANED MACROPHYTE AREA	MAINTENANCE ACCESS REQUIREMENTS
<1000m ²	Access path to > 40% of perimeter and all hydraulic controls Gravel, concrete or other trafficable material suitable for access on foot
≥ 1000m ² to < 5000m ²	Access path min 40% of perimeter ≥ 2.5m wide Gravel or concrete for light vehicles Remainder of perimeter ≥ 1.0m wide and all hydraulic structures
≥ 5000m ²	Access path 100% of perimeter and hydraulic structures ≥ 2.5m wide Cement treated gravel 200mm or concrete for large vehicles

3.6.3 MACROPHYTE ZONE MAINTENANCE ACCESS

PERFORMANCE OUTCOMES

Access to all areas of the wetland and hydraulic structures must be provided for regular inspections and maintenance.

RECOMMENDED APPROACH

Maintenance access is required to all parts of the wetland for general maintenance activities such as routine inspections, weed control, vegetation management, litter collection and hydraulic structure maintenance. The maintenance access around the wetland should be consistent with **Table 9** and local government requirements. Reinforced turf can also be used with approval from local authorities.



FIGURE 38 Photo maintenance edges

Photo by Glenn Browning – Water by Design

3.6.4 MAINTENANCE EDGES

PERFORMANCE OUTCOMES

Maintenance edges must:

- minimise the risk of turf and weeds encroaching into the wetland
- provide maintenance access to the wetland
- delineate the wetland from surrounding land uses (if required).

RECOMMENDED APPROACH

Maintenance edges minimise the risk of turf and weeds encroaching into the wetland. They separate

different landscape types, create clean edges to the batter planting, and permit easy maintenance of adjacent landscapes. Maintenance edges are not recommended for constructed wetlands located next to bushland or riparian vegetation. Maintenance edges should be located at the perimeter of wetland planting and consist of:

- pedestrian pathways or un-vegetated maintenance access tracks
- concrete landscape maintenance edge in line with local authority standards.

Design Note: Ephemeral Wetlands

Where the design intent is for the wetland to be ephemeral (i.e. not permanently ponded), the base of the wetland does not need to have a impermeable liner. Ephemeral wetlands can be designed to replicate natural wetland system such as Melaleuca forests.

3.6.5 LANDSCAPE INTEGRATION

PERFORMANCE OUTCOMES

All maintenance access must consider the broader landscape context and ensure that it does not detract from the amenity or result in unacceptable limitations on regular users of any open space.

RECOMMENDED APPROACH

The following should be adopted:

- Where possible maintenance access should be co-located with pedestrian paths to limit the amount of concrete. Practicalities with closing the shared path during maintenance need to be understood and discussed with Council during concept design development.
- In high profile locations it may be appropriate to screen the maintenance access with vegetation at the top of batter. This must be approved by Council in advance and must consider the type of vegetation (able to withstand periodic vehicle movements) and practicalities with safely using the access as required. An example is using concrete pavers with holes made available for the planting of Imperata cylindrical or similar native grasses.
- In situations where the maintenance access track is combined with pedestrian footpaths, the access track is typically 1.5 m wide with a flat vegetated edge of at least 0.5 m either side of footpath. Local authority requirements should be considered when combined footpaths are being considered.

3.7 Impermeable Liner and Topsoil

3.7.1 IMPERMEABLE LINER

PERFORMANCE OUTCOMES

The wetland liner should be impermeable to ensure the wetland does not leak or interact with surrounding groundwater.

RECOMMENDED APPROACH

Wetlands with a permanent pool have an impervious liner made from compacted site soils, and/or imported or manufactured material where site soils are unsuitable. Leakage through the base of the wetland will severely affect the vegetation and also the treatment performance of the wetland.

Impermeable liners should be used where the groundwater table is likely to interact with the wetland or where there are saline or acid sulfate in-situ soils.

Wetland liners should comprise of 300mm compacted clayey soils. The thickness of the clay liner required will be informed by the outcomes of the laboratory testing.

Generally, clay liners should meet the following criteria:

- 300mm thick
- cover the whole sediment basin and macrophyte zone up to the extended detention depth
- hydraulic conductivity of less than 1×10^{-9} m/s when tested under laboratory conditions with the soil remoulded to a density ratio of 95% standard compaction (+/- 2% from optimum moisture content).
- free of organic material (including vegetation and topsoil)

- free of rubble and deleterious material
- percentage of clay and silt fines (<75 micron) >40% minimum (preference is for >50% however) when tested in accordance with AS1289 3.6.1
- percentage gravel (>2.36 mm) <10% when tested in accordance with AS1289 3.6.1
- liquid limit – 25-60% when tested in accordance with AS1289 3.1.2
- plasticity index – 15-45% when tested in accordance with AS1289.3.2.1

Clay liner can be either compacted in-situ clay or imported clay. Geotechnical investigation must be completed to assess the suitability of in-situ clays and certified by a geotechnical engineer (Level 1 certification required).

Where no liner is proposed, in-situ geotechnical testing must be undertaken to determine the water retention capacity of the soils (i.e. whether the proposed soils in these areas will hold water).

Manufactured products, such as bentonite liners or HDPE membranes, may be considered for the wetland impermeable liner but are not preferred due to leakage risk. Given that constructed wetlands often have a complex shape and have at least one pipe connection through the liner, the seal between liner sheets and around perforations (e.g. around pipes and structures) must be robust. Proprietary liners and membranes should be 'keyed' into wetland batters by extending them at least 500 mm beyond the normal water level (i.e. up the batter) then pinned to the in-situ soil and covered with at least 200 mm of topsoil. Where an embankment surrounds the wetland, the liner should ideally extend over the embankment for reinforcement.



FIGURE 39 Clay impermeable liner installation

Photo by Robin Allison – DesignFlow



FIGURE 40 Synthetic liner installation

Photo by Glenn Browning - AECOM



FIGURE 41 Topsoil installation

Photo: Paul Dubowski – BMT WBM

3.7.2 TOPSOIL

PERFORMANCE OUTCOMES

The topsoil used in the wetland should be agronomically acceptable and capable of supporting aquatic plant growth

RECOMMENDED APPROACH

The provision of suitable topsoil in wetlands is crucial to successful water plant establishment and to the long term treatment performance of the wetland. Water plants typically prefer medium textured silty to sandy loams that allow for easy rhizome and root penetration.

Topsoil used within a constructed wetland (in situ or imported) must comply with AS 4419 Soils for Landscaping and Garden Use. Testing must be carried out by a NATA accredited laboratory, and if required, amendments to the topsoil undertaken to achieve compliance with AS 4419. It should be noted that the AS 4419 requirement for % organic matter content does not apply to topsoils used in wetlands. Topsoils used in wetlands must have a minimum of 5% organic matter content.

It is recommended that at least 200 mm topsoil be provided in all areas of the macrophyte zone (including the batters); and in sediment basins to 500 mm below NWL.

3.8 Vegetation Design

Constructed wetlands should have a dense cover of healthy, actively growing plants that help to remove pollutants from the stormwater. A well designed wetland will contain a range of vegetation types that:

- enable wetland performance objectives to be met
- integrates with surrounding landscapes (natural or created)
- suppresses weed growth
- thrives in the local climate
- enhances local biodiversity (where required)

Designing a wetland planting plan to meet these objectives requires consideration of vegetation

planting zones, species selection, planting density, planting set-out, and the type of mulch to be applied. This section contains recommendations for each of these aspects.

3.8.1 WETLAND PLANTING ZONES

The wetland vegetation generally comprises of three planting zones (**Figure 42**):

- Macrophyte zone vegetation (shallow, deep and submerged marshes) (NWL to -0.7 m)
- Ephemeral batter vegetation (NWL to +0.2 m)
- Terrestrial vegetation (above +0.2 m)

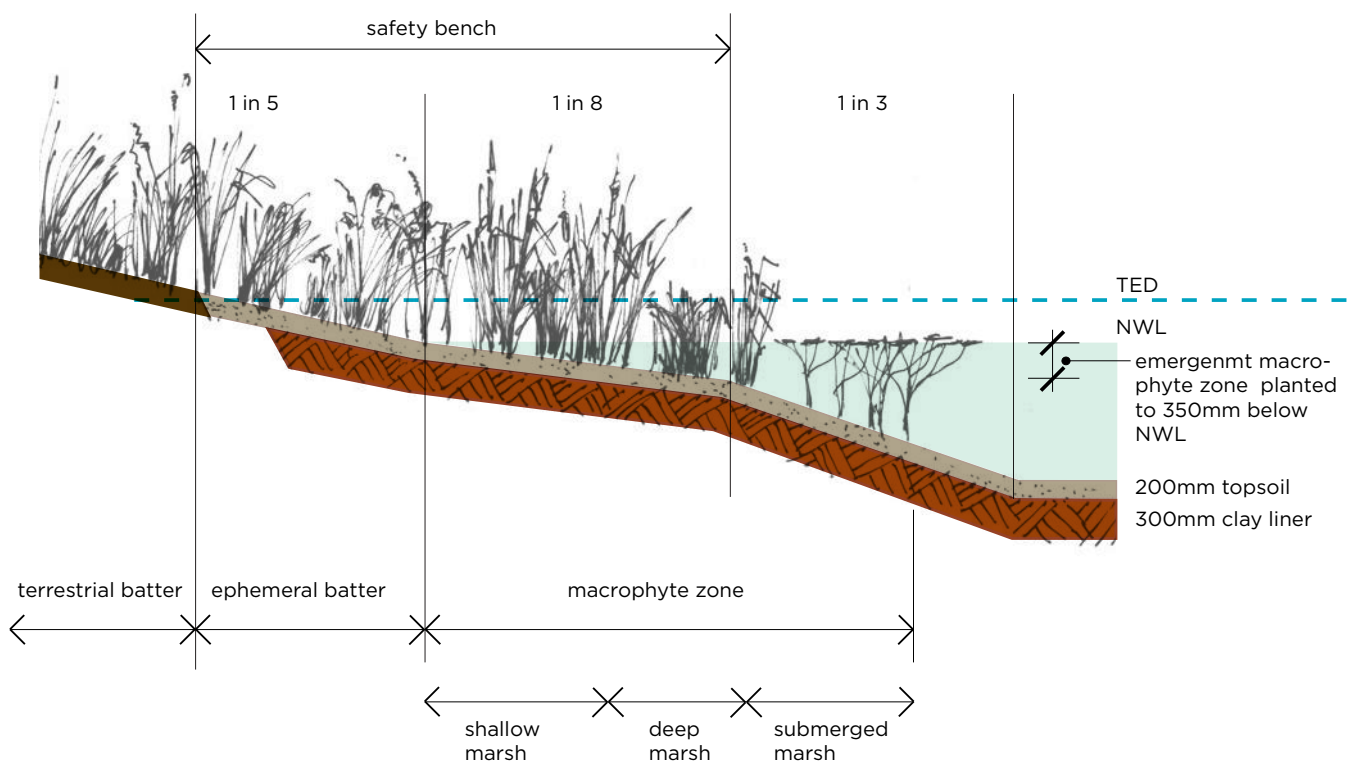

FIGURE 42 Wetland planting zones

3.8.1.1 MACROPHYTE ZONE VEGETATION (NWL TO -0.7 M)

The presence of water plants, also referred to as macrophytes, is crucial to ongoing treatment performance of a constructed wetland, as the plants play a major role in the uptake of nutrients, and the health of the wetland sediments and microbial communities. The wetland vegetation also provides a range of other functions including aesthetic, public safety and ecological services (Table 10)

A constructed wetland must be designed to provide optimal conditions for plant growth to ensure the ongoing treatment performance of the wetland. The bathymetry of the wetland macrophyte zone is designed so that the stormwater passes through a sequence of densely vegetated marsh zones (shallow, deep and submerged) before discharged

from the wetland outlet. The bands of water plants across the wetland ensure that the macrophyte zone cross section has uniform hydraulic conveyance.

The key plant attributes that influence pollutant uptake and facilitate the long-term persistence of the macrophyte vegetation includes:

- adaptations to grow in water (as emergent or submerged plant forms)
- ability to tolerate periods of inundation
- presence of rhizomatous root systems (facilitates spreading rather than clumped forms)
- most plants are perennial rather than annual
- simple vertical leaves (e.g. *Baumea* spp) which provide a high surface area for biofilm growth and interaction with the water column

TABLE 10 THE FUNCTION OF THE MACROPHYTE VEGETATION IN A CONSTRUCTED WETLAND.

FUNCTIONAL PROCESS	ROLE OF VEGETATION
Physical	Vegetation reduces inflow velocities and therefore protects the wetland base from scour. Reduction of inflow velocities promotes the settling of fine sediments from the water column to the bed of the wetland.
Chemical	Water plants transfer oxygen to the sediments helping to keep the sediments aerated and facilitating biochemical and microbial processes within the sediments.
Biological	Pollutants are trapped through adhesion to biofilms, or by direct uptake (absorption) by plants and biofilms. Plant roots and stems provide a substrate for microbial growth. Soil microbes facilitate decomposition and mineralisation of organic matter, nutrient uptake, nitrogen processing and heavy metal uptake. Root decay provides a continuous source of carbon used by denitrifying bacteria.
Ecological	Planting design and species selection can be used to re-create local plant communities and enhance local biodiversity. Wetland vegetation provides habitat for a range of native fauna. Dense vegetation suppresses weed growth.
Aesthetics	Wetland vegetation can be used to create a highly aesthetic environment that compliments adjacent public open spaces and enhances passive use of these areas. Vegetation can reduce visual impacts of a modified landscape, such as cut batters and bund formations. Tree plantings on batters can ensure that the existing tree canopy remain unbroken. Trees and shrubs planted on batters can screen and filter negative views to wetland infrastructure, including maintenance tracks, headwalls, and weirs.
Public safety	Vegetation planted on the batters and edge of the wetland can be used to prevent public access to open water zones in the wetland.

3.8.1.2 EPHEMERAL BATTER (NWL TO +0.2 M)

The ephemeral batter zone consists of a narrow band of vegetation around the lower margin of the wetland. The establishment of dense vegetation cover around the margin of the wetland is important to ensure that the lower batters are protected from scour and erosion. In many cases, the ephemeral batter vegetation also provides provide a buffer between the wetland water body and adjacent publicly accessible open space to discourage contact with the water.

The ephemeral batter zone is regularly inundated during the wet season as water levels in the wetland fluctuate in response to rainfall events.

The vegetation planted in the ephemeral batter should generally comprise of plant species adapted to regular wetting and drying sequences, including grasses, rushes, sedges and herbs. The ephemeral batter vegetation may also include riparian shrub and tree species such as *Melaleuca* spp.

3.8.1.3 TERRESTRIAL VEGETATION (GREATER THAN 0.2 M ABOVE NORMAL WATER LEVEL)

A range of terrestrial vegetation types may be planted on the upper wetland batter including groundcovers, shrubs and trees. Shrubs and trees are not a required element of wetlands but can be integrated to provide visual amenity, character and landscape value.

The selection of plant species for the terrestrial planting zone will be influenced by functional and landscape considerations such as:

- providing borders (edge plantings)
- screening vegetation
- maintaining view lines across the wetland
- restricting public access
- suppressing weed growth along the wetland margins (shading)
- facilitating public access

The terrestrial vegetation planted on the wetland batter often comprises of plant species which are found in the adjacent in local bushland ecosystems. This enables the wetland to be integrated within the surrounding landscape whilst increasing local biodiversity and providing additional habitat for local fauna.

3.8.2 SPECIES SELECTION

PERFORMANCE OUTCOMES

The plant species chosen for a constructed wetland must:

- enable wetland performance objectives to be met
- be capable of obtaining 80% plant cover within two growing seasons
- be suitable for the local landscape and ecology
- be suitable for the predicted wetting and drying regime (where applicable)
- be of local provenance (where applicable)
- meet local authority requirements

RECOMMENDED APPROACH

Planting a diverse range of plant species, including core plant species known to be successful in constructed wetlands, will ensure a higher likelihood of successful plant establishment, as well as long-term wetland treatment performance and resilience to changing conditions.



FIGURE 43 Macrophyte zone during establishment phase

Photo by Jason Sonneman – Design flow

MACROPHYTE ZONE

The plants selected for each of the macrophyte planting zones (shallow, deep and submerged marshes) must be able to tolerate the planting depth and expected wetland hydrologic regime.

Recommended core plant species for each of the macrophyte planting zones are provided in **Table 12**. Using these core plant species ensures that a minimum level of wetland performance will be achieved.

The plant species listed in **Table 12** have been grouped into shallow, deep and submerged marsh zones according to their tolerance to water depth, inundation and plant growth characteristics. While individual plant species may have very specific tolerances, other species may be able to grow across a range of depths and may be planted in both the shallow and deep marsh zones (e.g. *Lepironia articulata*).

A minimum of two core plant species must be selected for each macrophyte planting zone. A minimum of 75% of each macrophyte planting zone should be

planted with the core plant species listed in **Table 12**. The remainder of the macrophyte planting zone should be planted with supplementary plant species listed in **Table 13**, or species with the attributes listed in **Section 3.8.1.1**.

If a lower coverage of core plant species is proposed, a suitably qualified ecologist or landscape architect should confirm that the plant species selected will provide the performance outcomes outlined above.

Local climatic variations mean that some plant species may be more or less suited to certain locations within the regions identified in **Table 12** and **Table 13**. The local authority should be consulted to determine if the proposed plant species are suitable for a particular location.

The plant species listed for the shallow and deep marsh zones should also be used for edge planting (at equivalent depths) in sedimentation basins. It is generally prudent to plant tall emergent species around the margins of sediment basins to provide a vegetation screen and to prevent unauthorised access.

Inundation frequency and high spells analyses

STEP 1: INUNDATION FREQUENCY ANALYSIS

An inundation frequency analysis must be undertaken to determine the potential impacts of elevated wetland water levels on emergent water plant health in situations where the wetland water levels are likely to persist at an elevated level, at or above the top of extended detention (TED) for extended periods time. This may occur when the wetland:

- is undersized (<2%) compared to the contributing catchment area
- Is oversized (>7%) compared to the contribution catchment area
- has more than 0.5 m extended detention depth (EDD)
- has permanent base flows

As a general 'rule', it is recommended that effective water depth (permanent pool depth plus EDD) must not exceed half of the average plant height for more than 20% of the time.

Refer to the Melbourne Water Constructed Wetland Manual, Part D: Design tools, resources and glossary for detailed guidance on undertaking an inundation frequency analysis. <http://www.melbournewater.com.au/planning-and-building/standards-and-specifications/design-wsud/pages/constructed-wetlands-design-manual.aspx>

STEP 2: HIGH SPELLS ANALYSIS

A high spells analysis should also be undertaken to assess the maximum duration that the wetland water levels will be elevated at or above the TED. The persistence of elevated water levels within the wetland for extended periods of time (e.g., more than one week) has the potential to impact on water plant health, particularly when more than half of the plant height is inundated.

A high spells analysis can be undertaken by importing the wetland water levels from the MUSIC flux file into the River Analysis Package (available from the eWater website: <http://www.ewater.org.au>)

STEP 3: RISK ASSESSMENT

The inundation frequency and high spells analyses should be used to assess whether the plant species proposed for the shallow and deep marsh zones are able to cope with the expected wetland hydrology. An experienced wetland ecologist should be consulted to assess the high spells results, and to determine whether the predicted wetland inundation durations determined by the high spells analysis represent a risk to the wetland vegetation.

The wetland planting plan must be adjusted if a plant species is unable to satisfy the inundation frequency 'rule' or the high spells analysis indicates that the wetland water level will remain at a high level for extended periods of time.

EPHEMERAL BATTER ZONE

A range of suitable plant species for the ephemeral batter and terrestrial planting zones is provided in **Table 12**. Note: There is no minimum species number requirement for the ephemeral batter and terrestrial planting zones.

The ephemeral batter zone will be regularly inundated during the wet season, and should generally comprise of plant species adapted to regular wetting and drying. A number of ephemeral batter species grow in moist sediments or shallow water (less than 50 mm depth), and should be planted along the interface between the ephemeral batter and the shallow marsh zone (i.e. slightly above or below NWL). These species are identified in **Table 12**, and should be clearly distinguished in the wetland planting plan. Generally, plants that have a drier habitat should be planted towards the top of the ephemeral batter zone, whereas those that are adapted to more moist conditions should be planted closer to the water line.

Planting groundcovers with matting or rhizomatous root systems in the ephemeral batter zone will assist in binding the soil surface during the plant establishment phase, and assist with preventing weed growth. Shrubs and trees may also be planted into the ephemeral batter zone, however care must be taken to select species such as Melaleuca that allow sunlight to penetrate the tree canopy, therefore preventing the macrophyte zone plants from being shaded out.

A major consideration when selecting plants for the ephemeral batter is providing adequate maintenance access to the wetland margin. Weed growth within the ephemeral batter zone is often a major wetland maintenance issue, particularly where Para grass (*Urochloa mutica*) is present. Para grass is an aquatic grass species that can rapidly grow out from the wetland margins into the macrophyte zone vegetation. Once established in a wetland, Para grass can be extremely difficult to remove without damaging the wetland vegetation. If Para grass is present, the ephemeral batter zone must be easy to access and monitor. This may require the planting of low profile groundcover plant species.

Establishment of densely growing, rhizomatous grass species such as Common couch (*Cynodon dactylon*) or Swamp Ricegrass (*Leersia hexandra*) within the ephemeral batter zone can be used to manage Para grass growth along the wetland margins. Both of these species form dense thickets which resist Para grass establishment, and the narrow form and color of the grass foliage enables the Para grass to be readily identified during maintenance inspections.

An alternative to establishing grass cover is to increase the planting density within the ephemeral batter. This can be an effective method to manage the growth of low priority weeds, however it is generally ineffective where Para grass is present.

TERRESTRIAL ZONE

The selection of plant species for the terrestrial planting zone (upper batter) is generally influenced by functional and landscape considerations such as providing borders (edge plantings); screening; maintaining view lines; restricting public access; weed suppression; or facilitating maintenance access.

A variety of different landscape treatments can be established in the terrestrial zone including:

- vegetation similar to adjacent parkland areas
- formal garden beds,
- mixed native plantings
- turf

Generally a terrestrial planting layout is chosen to visually integrate the wetland with its surrounds, however vegetation of contrasting species and/or layout may be selected to highlight the water body as a feature within the landscape.

Where a native planting style is proposed, the plant species should preferably be of local origin to preserve local biodiversity and to use plant species that are suited to local climatic conditions. The selection of plant species that form natural associations in local bushland ecosystems also ensures that many subtle components of the local ecosystems are preserved, such as food and habitat resources for insects and birds that are specific to particular plant species associations. Regional ecosystem descriptions should be consulted for guidance on plant species selection. Local government landscape strategies or plant selection guidelines may also help with choosing suitable species for the terrestrial zone.

In a drier climates, or climates with prolonged dry periods (e.g. Mackay and Townsville), locally occurring drought resistant plant species should be used in the terrestrial vegetation zone to increase the resilience of the system to climatic variables and other stressors.

TABLE 11 WETLAND PLANTING ZONES.

ID	PLANTING ZONE	DEPTH RANGE
TE	Terrestrial	> +0.2 m
EB	Ephemeral batter	NWL to +0.2 m
SM	Shallow marsh	NWL to -0.2 m
DM	Deep marsh	-0.2 m to -0.4 m
SU	Submerged marsh	-0.4 m to -0.7 m

PROPOSED LIFEFORMS:

- F - Floating macrophyte
- S - Submerged macrophyte
- E - Emergent macrophyte
- G - Groundcover
- SH - Shrub
- T - Tree

TABLE 12 CORE FUNCTIONAL PLANT SPECIES FOR THE SHALLOW MARSH, DEEP MARSH AND SUBMERGED MARSH ZONES

SPECIES NAME	COMMON NAME	PLANTING ZONE	LIFEFORM	HEIGHT (MM)	PLANTING DENSITY (PLANTS/M ²)	REGION			
						SEQ	CENTRAL COAST	MACKAY	TOWNSVILLE
<i>Actinoscirpus grossus</i>	Giant Bur Rush	SM, DM	E	1200-2000					✓
<i>Baumea articulata</i>	Jointed Twig-rush	DM	E	1000-2000	4-6	✓	✓	✓	✓
<i>Bolboschoenus caldwellii</i>	Sea Club-rush	SM	E	300-900	4-6	✓	✓		
<i>Bolboschoenus fluviatilis</i>	Marsh Club-rush	DM	E	1000-2000	4-6	✓	✓	✓	
<i>Cladium procerum</i>	Leafy twig-rush	SM, DM	E	1000-2500	4-6	✓	✓		
<i>Eleocharis acuta</i>	Common Spike-rush	SM	E	300-700	6-8	✓			
<i>Eleocharis dulcis</i>	Chinese Water Chestnut	SM, DM	E	800-1500	6-8	✓	✓	✓	✓
<i>Eleocharis equisetina</i>	Spike-rush	SM	E	500-1000	6-8	✓	✓		
<i>Eleocharis sphacelata</i>	Tall Spike-rush	DM	E	500-2000	6-8	✓	✓	✓	
<i>Lepironia articulata</i>	Grey Rush	SM, DM	E	600-2300	4-6	✓	✓	✓	
<i>Phragmites australis</i>	Common reed	SM, DM	E	1500-3000	4-6	✓	✓	✓	✓
<i>Schoenoplectus subulatus</i>	Shore Club-rush	SM, DM	E	600-2000	6-8	✓	✓	✓	✓
<i>Schoenoplectus validus</i>	River Club-rush	SM	E	600-1600	6-8	✓	✓	✓	✓
<i>Triglochin procera</i>	Water-ribbon	SM, DM	F	200-500	4-6	✓	✓		
<i>Ceratophyllum demersum</i>	Hornwort	SU	S	NA	1	✓	✓	✓	✓
<i>Hydrilla verticillata</i>	Water thyme	SU	S	NA	1	✓	✓	✓	✓
<i>Myriophyllum verrucosum</i>	Red Water-milfoil	SU	S	NA	1	✓	✓		
<i>Potamogeton ochreateus</i>	Blunt Pondweed	SU	S	NA	1	✓			
<i>Vallisneria australis</i>	Ribbonweed	SU	S	NA	1	✓	✓		

TABLE 13 SUPPLEMENTARY PLANT SPECIES FOR THE SHALLOW MARSH, DEEP MARSH, SUBMERGED MARSH AND EPHEMERAL BATTER ZONES.

SPECIES NAME	COMMON NAME	PLANTING ZONE	LIFEFORM	HEIGHT (MM)	PLANTING DENSITY (PLANTS/M ²)	REGION			
						SEQ	CENTRAL COAST	MACKAY	TOWNSVILLE
<i>Baumea arthropphylla</i> Wet edge only	Fine Twig-rush	EB, SM	E	800-1000	6-8	✓			
<i>Baumea juncea</i> Wet edge only	Bare Twig-rush	EB, SM	E	500-900	6-8	✓	✓	✓	✓
<i>Baumea rubiginosa</i> Wet edge only	Soft Twig-rush	EB	E	500-1100	6-8	✓	✓	✓	✓
<i>Carex appressa</i>	Tall Sedge	EB	E	900	6-8	✓	✓		
<i>Carex fascicularis</i> Wet edge only	Tassel Sedge	SM	E	500-1000	6-8	✓	✓		
<i>Carex gaudichadiana</i> Wet edge only	Tufted sedge	SM	E	300-500	6-8	✓			
<i>Carex polyantha</i> Wet edge only	Creek Sedge	EB	E	1000	6-8	✓	✓		
<i>Cyperus alopecuroides</i>	Foxtail Flat Sedge	EB, SM	E	1000-2000	4-6			✓	✓
<i>Cyperus exaltatus</i> Wet edge only	Giant Sedge	SM	E	1000-2000	6-8				
<i>Cyperus gunnii</i> Wet edge only	Flecked Flat Sedge	EB	E	1500	6-8	✓	✓	✓	✓
<i>Cyperus javanicus</i>	Javanese Flat Sedge	EB	E	600	6-8		✓	✓	✓
<i>Cyperus polystachyos</i>	Bunchy Sedge	EB	E	600	6-8	✓	✓	✓	✓
<i>Eleocharis geniculata</i>	Nodding Spike-rush	EM	E	500-600	6-8	✓	✓	✓	✓
<i>Ficinia nodosa</i>	Knobby Club-rush	EB	E	500-1000	6-8	✓	✓		
<i>Isolepis inundata</i> Wet edge only	Swamp Club-rush	SM	E	400	6-8	✓	✓	✓	✓
<i>Juncus flavidus</i>	Yellow Rush	EB	E	1000	6-8	✓			
<i>Juncus kraussii</i>	Sea Rush	EB, SM	E	500-1500	6-8	✓	✓		
<i>Juncus prismatocarpus</i> Wet edge only	Branching Rush	EB, SM	E	400-500	6-8	✓	✓		
<i>Juncus usitatus</i> Wet edge only	Common Rush	EB	E	400-1100	6-8	✓	✓	✓	✓
<i>Ludwigia peploides</i> Wet edge only	Water Primrose	EB	E	400	4-6	✓	✓	✓	✓
<i>Phylidrium lanuginosum</i>	Woolly Water Lily	SM	E	500-1000	2-4	✓	✓	✓	✓
<i>Schoenoplectus mucronatus</i>	Bog Bulrush	SM	E	350-1000	6-8	✓	✓	✓	✓
<i>Marsilea crenata</i>	Nardoo	SM	F	NA	2			✓	✓
<i>Marsilea drummondii</i>	Common Nardoo	SM	F	NA	2	✓	✓		

SPECIES NAME	COMMON NAME	PLANTING ZONE	LIFE-FORM	HEIGHT (MM)	PLANTING DENSITY (PLANTS/M ²)	REGION			
						SEQ	CENTRAL COAST	MACKAY	TOWNSVILLE
<i>Marsilea mutica</i>	Banded Nardoo	SM	F	NA	2	✓	✓	✓	✓
<i>Nymphaea gigantea</i>	Blue Water Lily	SU	F	NA	1	✓	✓	✓	✓
<i>Bacopa monnieri</i> Wet edge only	Bacopa	EB	G	80	6-8	✓	✓	✓	
<i>Baloskion pallens</i> Wet edge only	Cord Rush	EB	G	500-1000	6-8	✓	✓		
<i>Baloskion tetraphyllum</i> Wet edge only	Tassel Cord-rush	EB	G	500-1600	6-8	✓	✓		
<i>Cynodon dactylon</i>	Common couch	EB	G	250	6-8	✓	✓	✓	✓
<i>Eclipta prostrata</i>	White Eclipta	EB	G	300	4-6	✓	✓	✓	✓
<i>Gahnia clarkei</i>	Tall Saw-sedge	EB	G	1000-2000	4-6	✓	✓		
<i>Gahnia siberiana</i>	Red-fruited Sword Sedge	EB	G	1500-3000	4-6	✓	✓	✓	
<i>Imperata cylindrica</i>	Blady Grass	EB	G	500-900	6-8	✓	✓	✓	✓
<i>Ischaemum australe</i> Wet edge only	Southern Grass	EB, SM	G	1200	4-6	✓	✓	✓	✓
<i>Ischaemum rugosum</i> Wet edge only	Ribbed Muraina Grass	EB, SM	G	1200	4-6			✓	✓
<i>Leersia hexandra</i>	Swamp Rice Grass	EB, SM	G	400-1200	6-8	✓	✓	✓	✓
<i>Lepidosperma longitudinale</i>	Common Sword-sedge	EB	G	600-2000	6-8	✓	✓		
<i>Leptochloa neesii</i> Wet edge only	Umbrella Canegrass	EB, SM	G	600-1500	6-8				✓
<i>Lomandra hystrix</i>	River Mat Rush	EB	G	1200	4-6	✓	✓	✓	✓
<i>Lomandra longifolia</i>	Spiny-headed Mat Rush	EB	G	1000	4-6	✓	✓	✓	✓
<i>Oryza australiensis</i> Wet edge only	Native Rice	EB	G	1200	6-8			✓	✓
<i>Panicum decipiens</i> Wet edge only	Slender Knotweed	EB	G	300-500	6-8	✓	✓	✓	✓
<i>Panicum strigosum</i> Wet edge only	Spotted Knotweed	EB	G	350-600	6-8	✓	✓	✓	✓
<i>Poa labillardieri</i>	Tussock Grass	EB	G	800-1300	6-8	✓	✓		
<i>Pseudoraphis spinescens</i> Wet edge only	Spiny Mud Grass	EB	G	250-500	6-8	✓	✓	✓	✓
<i>Leptospermum liversidgei</i>	Lemon-scented Tea-tree	EB	SH			✓			
<i>Myriophyllum verrucosum</i>	Red Water Milfoil	DM, SU	S	NA	1	✓	✓	✓	✓

SPECIES NAME	COMMON NAME	PLANTING ZONE	LIFE-FORM	HEIGHT (MM)	PLANTING DENSITY (PLANTS/M ²)	REGION			
						SEQ	CENTRAL COAST	MACKAY	TOWNSVILLE
<i>Potamogeton tricarlinatus</i>	Floating Pondweed	SU	S	NA	0.5	✓	✓	✓	✓
<i>Casuarina cunninghamiana</i>	River She-oak	EB	T			✓	✓	✓	✓
<i>Cupaniopsis anacardioides</i>	Beach Tuckeroo	EB	T					✓	
<i>Elaeocarpus grandis</i>	Blue Quandong	EB	T					✓	✓
<i>Eucalyptus tereticornis</i>	Queensland Blue Gum	EB	T			✓	✓	✓	✓
<i>Hibiscus tiliaceus</i>	Cotton Wood	EB	T			✓	✓	✓	✓
<i>Livistonia decora</i>	Weeping Cabbage Palm	EB	T					✓	
<i>Lophostemon suaveolens</i>	Swamp Mahogany	EB	T			✓	✓	✓	
<i>Melaleuca bracteata</i>	River Tea Tree	EB	T			✓	✓		
<i>Melaleuca dealbata</i>	Blue-leaved Paperbark	EB	T				✓	✓	✓
<i>Melaleuca leucadendra</i>	Weeping Paperbark	EB	T					✓	✓
<i>Melaleuca linariifolia</i>	Flax-leaf Paperbark	EB	T			✓			
<i>Melaleuca nodosa</i>	Prickly-leaved Paperbark	EB	T			✓	✓		
<i>Melaleuca quinquenervia</i>	Broad-leaved Paperbark	EB	T			✓	✓		
<i>Melaleuca salicina</i>	Willow Bottlebrush	EB	T			✓	✓		
<i>Melaleuca viminalis</i>	Weeping Bottle Brush	EB	T			✓	✓	✓	✓
<i>Melaleuca viridiflora</i>	Broad-leaved Paperbark	EB	T				✓	✓	✓
<i>Nauclea orientalis</i>	Leichhardt Tree	EB	T					✓	✓
<i>Syzygium australe</i>	Creek Cherry	EB	T			✓	✓	✓	✓
<i>Waterhousea floribunda</i>	Weeping Lily Pily	EB	T			✓	✓	✓	



FIGURE 44 Purple swamp hen

Photo by Jack Mullaly - Ideanthro

3.8.3 SPECIES SELECTION FOR RESISTANCE TO WATER BIRDS

The presence of waterbirds, particularly Purple Swamp Hens (**Figure 44**), can result in notable damage to the emergent water plants and ultimately widespread removal of wetland vegetation cover. Soft palatable water plant species such as *Baumea articulata* and *Schoenoplectus validus* are particularly susceptible to waterbird pressure, as the stems of these species can be easily broken and used by the birds for nesting, loafing and building elevated lanes for traversing standing water areas.

A number of alternative water plant species may be planted which do not provide ideal habitat for water birds. These are generally robust emergent species which cannot be readily damaged by water bird grazing. These include:

- *Bolboschoenus fluviatilis*
- *Bolboschoenus caldwellii*

- *Cladium procerum*
- *Cyperus exaltatus*
- *Lepironia articulata*
- *Phragmites australis*

Alternative options for managing water bird damage includes the use of larger tube stock sizes such as 600 cm³ pots (as compared to standard 200 cm³ forestry tubes). Seedlings grown in larger pots are generally characterised by larger, well developed root systems that provide a larger anchor area in the sediment, and enable the plant to withstand water bird grazing. Seedlings grown in larger pots also have taller foliage. This means that more of the foliage is above the wetland water level during establishment, resulting in more rapid plant establishment and resilience to inundation.

In some circumstances, netting may be required to protect species that are particularly susceptible to water bird grazing pressure during the establishment period such as *Triglochin procerum*.

3.8.4 PLANTING DENSITY

PERFORMANCE OUTCOMES

Planting densities must:

- enable 80% plant coverage of the wetland within two growing seasons
- enable wetland treatment performance objectives to be met
- provide rapid coverage to out-compete weeds

RECOMMENDED APPROACH

The use of high planting densities in constructed wetlands is beneficial to:

- facilitate rapid establishment of vegetation cover
- exclude weeds
- maximise pollutant removal
- distribute flows evenly across the wetland
- prevent scour, establishment of preferred flow paths, and re-suspension of deposited sediments.

A suitable planting density should be used to ensure that at least 80% vegetation cover of the wetland macrophyte zone is achieved after two growing seasons (i.e. plant establishment period).

The planting density required to achieve this outcome will vary depending on individual species growth characteristics. For example, plant species with rhizomatous root systems will require a lower planting density as the plant is able to expand into the gaps between the vegetation. In contrast, a higher planting density will be required for plant species with rhizomatous root systems that do not spread aggressively and grow as a clumped form, or plant species that do not have rhizomatous root systems.

Minimum recommended planting densities that enable vegetation cover to be rapidly established

in the wetland are provided in **Table 12** and **Table 13**. The planting densities required for constructed wetlands in the Mackay and Townsville regions are substantially less than those recommended for South East Queensland due to the rapid water plant growth observed in these regions. It is recommended that the planting densities listed in **Table 12** and **Table 13** should be halved for these regions.

Wetlands are dynamic environments, and the wetland vegetation cover can be expected to vary over time in response to disturbance events and natural vegetation succession. This may result in the development of a more open wetland vegetation structure and a reduction in the overall vegetation cover. The adoption of high planting densities will help to ensure that there is sufficient individual plants to withstand potential disturbance and that overall long term vegetation cover is maintained within the wetland.

Direct seeding may be a useful alternative to the use of seedlings, particularly in large wetland systems where it is important to establish vegetation cover quickly to minimise weed ingress. Direct seeding is commonly used for establishing grass cover in bush reconstruction projects, and can be used to establish groundcovers, shrubs and trees within the ephemeral batter and terrestrial planting zones.

The use of direct seeding in combination with hydromulches can be an effective method for stabilising the wetland batters during establishment. Note that hydromulch is susceptible to scour from medium to high flow conditions.

As the success rate of direct seeding cannot be guaranteed, direct seeding should be used to complement planting seedlings.



Figure 45 Plant setout and planting

Photo: Shaun Leinster

3.8.5 PLANTING SET-OUT

PERFORMANCE OUTCOMES

The planting set-out for the vegetation planted in the macrophyte zone must minimise the risk of bare patches developing if one species fails.

RECOMMENDED APPROACH

A minimum of two core plant species should be planted in each of the macrophyte planting zones to minimise the risk of bare patches developing if one species fails.

It is recommended that most water plant species are planted in small clumps of 5–10 plants of the same species to ensure propagation can readily occur. Where plants are installed in large bands of a single species, the designer must be confident the species will survive.

The planting set-out for groundcovers, shrubs and trees in the ephemeral batter and terrestrial planting zones is more flexible. The plant set-up on the batters can involve:

- a random distribution to provide shade cover and weed suppression
- clumping of several groundcovers (grasses, sedges, rushes), shrubs and trees as would occur naturally
- structured planting to provide viewlines across the wetland or to prevent unauthorised access to the wetland

The wetland planting set-out should be clearly shown on a plan indicating:

- planting zones and levels
- plant densities
- plant species for each planting zone
- planting arrangement (required species mix)

3.8.6 MULCH FOR TERRESTRIAL PLANTINGS

PERFORMANCE OUTCOMES

The mulch used for the terrestrial planting zone must:

- ensure adequate soil moisture for plant health
- suppress weeds
- not hinder plant growth

RECOMMENDED APPROACH

Lack of adequate soil moisture, particularly in areas that experience hot dry conditions, is often a major reason for vegetation failing. Mulch should be applied to batter plantings down to TED until plants establish to help insulate and retain moisture within the topsoil, and to suppress weeds. Mulch layers should be 50–75 mm deep to ensure that plants are not hindered. Mulch placed from the normal water level to top of extended detention should be pinned down with an open weave organic mesh or jutemat should be adopted.

Further information about selecting mulch material is in Section and the *Construction and Establishment Guidelines: Swales, Bioretention Systems and Wetlands (Water by Design)*.

3.8.7 RESILIENCE TO CLIMATIC VARIATIONS

PERFORMANCE OUTCOME

Constructed wetlands are installed in widely varying climatic regions. To ensure that constructed wetlands function, and particularly that vegetation survives, wetland design must be resilient and respond to local climatic conditions.

RECOMMENDED APPROACH

In dry climates, or climates with extended dry periods (those with low rainfall and/ or high evapotranspiration) wetland systems should employ the following techniques to ensure plant survival.

- Installing locally relevant drought tolerant species (see **Section 3.8**).
- Ensuring the outlet riser can be easily adapted in response to climatic conditions.

Plant survival can also be enhanced by:

- Increase depth of normal water level to provide for evapotranspiration
- Installing trees and/ or shrubs in and around the wetland system to produce a canopy which cools the system and reduces evapotranspiration (see **Section 3.8**).
- Supplemental irrigation during the dry season

3.8.8 DESIGN CALCULATION SUMMARY

Following is a design calculation summary sheet for the key design elements.

CONSTRUCTED WETLANDS DESIGN CALCULATION SUMMARY

CALCULATION TASK		CALCULATION SUMMARY		
		OUTCOME		CHECK
CATCHMENT CHARACTERISTICS				
	Catchment area		ha	
	Catchment land use (i.e residential, commercial etc.)			
	Storm event entering inlet pond (minor or major)			
CONCEPTUAL DESIGN				
	Macrophyte zone area		m ²	
	Permanent pool level of macrophyte zone		m AHD	
	Extended detention depth (0.25-0.5m)		m	
	Notional detention time		hrs	
1 CONFIRM TREATMENT PERFORMANCE OF CONCEPT DESIGN				
	Total suspended solids		% removal	
	Total phosphorus		% removal	
	Total nitrogen		% removal	
2 DETERMINE DESIGN FLOWS				
	'Design flow' (1 year ARI)		year ARI	
	'Above design flow' (2-100 year ARI)		year ARI	
	TIME OF CONCENTRATION (refer to relevant local government guidelines and QUDM)		minutes	
IDENTIFY RAINFALL INTENSITIES	'Design flow' - _{1 year ARI}		mm/hr	
	'Above design flow' - _{2-100 year ARI}		mm/hr	
PEAK DESIGN FLOWS	'Design flow' 1 year ARI		m ³ /s	
	'Above design flow' – 2-100 year ARI		m ³ /s	

CONSTRUCTED WETLANDS DESIGN CALCULATION SUMMARY

CALCULATION TASK		CALCULATION SUMMARY		
		OUTCOME		CHECK
5 DESIGN MACROPHYTE ZONE OUTLET				
	RISER OUTLET	Target maximum discharge (Qmax)	m ³ /s	
		Uniform Detention Time Relationship for Riser		
	MAINTENANCE DRAIN	Maintenance drainage rate (drain over 12hrs)	m ³ /s	
		Diameter of maintenance drain pipe	mm	
		Diameter of maintenance drain valve	mm	
	DISCHARGE PIPE	Diameter of discharge pipe	mm	
6 DESIGN HIGH FLOW BY-PASS 'CHANNEL'				
		Longitudinal slope	%	
		Base width	m	
		Batter slopes	H:V	
7 VERIFICATION CHECKS				
		Macrophyte zone re-suspension protection		
		Confirm treatment performance		

3.9 Detailed design documentation

It is important to document the detailed design of the wetland, both for construction and for the development approvals process (if required). The following documents should be submitted to the approval authority as a detailed design package:

- Design checklist or Design report.
- Detailed design drawings.
- Specifications.

3.9.1 DESIGN CHECKLIST

Where the size of the wetland and associated catchments has not changed since the conceptual design report (or stormwater management plan), the only the Design Checklist needs to be filled out and submitted with the design drawings and specifications.

3.9.2 DESIGN REPORT

Where the wetland and associated catchment have changed since the conceptual design report (or stormwater management plan), then a Design Report needs to be document. The wetland design report should document all technical aspects of the wetland design including the analysis methods, calculations and assumptions made during the design process. The design report should identify any unique maintenance requirements and evidence that the ultimate asset owner is satisfied with these requirements.

The design report should include:

- description of design intent and system operation
- description of the MUSIC model and treatment results
- design flow rates, and the method and assumptions used to estimate them
- calculations used to size the:
 - sediment basin
 - high flow bypass channel
 - connection between the sediment basin and macrophyte zone
 - connection between the sediment basin and high flow bypass
 - wetland outlet control
 - macrophyte zone overflow outlet
 - maximum flow velocities through the sediment basin and macrophyte zone
 - scour protection and energy dissipation works
 - sediment dewatering area (if applicable)
- summary of key design parameters
- inundation frequency analysis (if applicable)
- detailed design drawings (civil and landscape construction drawings)
- proposed construction and establishment methodology (including erosion and sediment control measures)
- design checklist

The design report should also refer to local standards for any other specific reporting requirements such as the *Urban Stormwater Quality Planning Guidelines* (DERM, 2010).

3.9.3 DETAILED DESIGN DRAWINGS

The detailed design drawings comprises of both civil engineering and landscape drawings suitable for design approval and construction tendering. The drawings should clearly detail the design of the constructed wetland, including all elements developed during the detailed design process.

The final design drawings must be suitably scaled and annotated and include:

- Relevant references to IPWEAQ standard drawings
- Plan view showing:
 - Location of wetland relative to existing features (e.g. adjacent waterways, road reserves, property boundaries and public open space)
 - Design levels and earthworks to illustrate wetland profile (including contours and spot heights)
 - Location and details of the wetland inflows and outflows
 - Location and details of hydraulic structures (e.g. pipe connections, pits, headwalls and weirs)
 - Maintenance access
 - Sediment dewatering area
 - Pedestrian pathways
 - Existing services (i.e. gas mains)
 - Tree protection zones or areas of existing vegetation to be retained
- Cross sections of the wetland profile and interaction with surrounds, illustrating:
 - Normal water level
 - Top of extended detention
 - Batter slopes and embankment levels
 - Details of impervious liner
 - Details of topsoil layer
 - Inflow and outflow pipes
 - Connection between the sediment basin and macrophyte zone
 - Connection between the sediment basin and high flow bypass
 - Wetland outlet control pit
 - Macrophyte zone overflow outlet

- Dimensions and details of:
 - Inflow and outflow pipes
 - Hydraulic infrastructure (e.g. pipes, pits, headwalls and weirs)
 - Base of sediment basin
 - Maintenance access track
 - Maintenance edges (e.g. concrete edge strip)
 - Fencing and signage
 - Water level gauge (if required)
- Planting layout indicating the planting zones
- Planting schedule specifying:
 - a plant list for each planting zone (using scientific names)
 - plant container size
 - planting density (per m²)
 - number of plants per planting zone
- Set-out plan
- Notes including:
 - Civil and landscape specifications
 - Construction and establishment requirements

3.9.4 SPECIFICATIONS

Civil and landscape specifications outlining the construction and establishment methods, tolerances, and materials must be documented for assessment and construction. Typically this can be done by either including the specifications as notes on the detailed design drawings, producing a standalone specification document or a combination of both. The most important consideration is that anyone either assessing or constructing the system must be able to easily access the information contained within the specifications. For this reason, even if a standalone specification document is produced, the detailed design drawings and design report must make mention of the specification document.

An example of civil and landscape specifications for constructed wetlands is provided in **Chapter 4**.



Chapter 4 Specification

Photo: Glenn Browning AECOM

4.1 How to use this section

This section provides standard specifications for typical constructed wetlands. Relevant sections of the specifications can be used as an example or copied directly into tender packages. When using the standard specifications, designers should ensure:

- the standard specification is relevant to their particular constructed wetland design
- the final specification includes any information that is not covered in this standard specification.

4.2 Civil construction

4.2.1 TOLERANCES

Constructed wetlands must be constructed within the tolerances shown in **Table 14**.

TABLE 14 WETLAND TOLERANCES

WETLAND ELEMENT	CONSTRUCTION CONSIDERATIONS	TOLERANCE
Hydraulic structures (overflow pit, pipe and weirs)	These structures control the movement of water through the system. Tolerances apply to: <ul style="list-style-type: none">• inlet pipes• overflow pit crest level• pipe connections to macrophyte zone• outlet riser• outlet pipe invert (upstream and downstream)• weirs	± 25 mm
Earthworks (base)	The base of the macrophyte zone is critical for planting depth	± 50 mm
Embankments and bunds	These contain water within the extended detention and when required, force runoff to the overflow structure.	- 25 mm + 50 mm Preference for bund to be higher rather than lower

TABLE 15 HYDRAULIC STRUCTURES IN WETLAND SYSTEMS

HYDRAULIC STRUCTURE	DESCRIPTION	CONSTRUCTION REQUIREMENTS
Overflow pit	Collects the design flow. Transfers collected flows to the macrophyte zone	Concrete construction. Refer to drawings, local authority standards, or the IPWEA Standard Drawings for details. Pipes must be sealed into the overflow pit. Note: The crest is intentionally set lower than the embankment or bund.
Overflow weir	Transfers large flood flows out of the constructed wetland to the high flow bypass channel.	Mass concrete crest, typically 500 mm deep with reinforcing. Refer to drawings, local authority standards, or the IPWEA Standard Drawings for details. Rock mattress protection on both sides of crest to at least the base of the batters. Concrete and rock protection extending up batters and into bunds or batters at the ends of the weir. Refer drawings, local authority standards, or the IPWEA Standard Drawings for details.
Outlet riser	Allows water to slowly discharge from the wetland	Refer to drawings for location, size, orifice diameter and levels, and class of pipe. Refer local authority standards, or the IPWEA Standard Drawings for details.
Outlet pipes	Transfer flows from outlet riser to receiving systems.	Refer to drawings for location, size, levels, and class of pipe. Rock protection may be required at the outfall of the pipe (refer to drawings). Must be free draining, sealed to the outlet riser pit and include a seepage collar.

4.2.2 HYDRAULIC STRUCTURES

A description of hydraulic structures and the corresponding construction requirements is in **Table 15**.

4.2.3 IMPERMEABLE LINER

Constructed wetlands require an impermeable liner below the topsoil layer, up to the top of extended detention or higher as shown on design plans. Care should be given to ensuring that liners create an impermeable seal around all relevant hydraulic connections. The liner must achieve a hydraulic conductivity of less than 1×10^{-9} m/s. Liners should be made of 300mm compacted in-situ clay or imported clay.

Whether in-situ or imported clays are to be used, a geotechnical expert must sample and test the liner to certify the construction meets required permeability requirements. This involves testing of the material in laboratory as well as in-situ compaction tests. Testing shall follow this specification and with AS1289. Testing frequency for installed clay liner shall be:

- Field density (including moisture content) – one test per layer per 500m² or as otherwise directed
- Atterberg limits and grading – one test per layer per 1,000m² or as otherwise directed

Following installation of the liner, hydraulic structures are constructed that involve pipe connections often through the impervious liner (e.g. from a sediment basin to macrophyte zone or outlet pit within an embankment). It is critical that the liner is intact at these connection points and adequate attention is paid to re-establishing a waterproof seal.

Where synthetic liners are used, the following conditions must be met:

- The contractor must receive written assurance from the manufacturer that the product has a permeability of no greater than 1×10^{-9} m/s.
- Specific written advice on sealing the liner around protrusions (e.g. outlet pipes) must be obtained from the manufacturer.

- Liners must be installed and sealed in accordance with manufacturer's specifications and appropriately keyed into the batters and embankments to ensure the system is watertight.

Certification that the liner has been installed in accordance with the manufacturer's specifications and that it is watertight must be provided by a geotechnical engineer (Level 1 supervision and certification preferred).

4.2.4 SERVICES

In accordance with **Section 3.3.4**, underground services should be located outside the treatment zone, but may be incorporated into wetland batters or embankments. An impermeable barrier should separate the treatment zone and the service. Where there is no alternative to running services through a constructed wetland, services should be located in conduits running between pits at either end of the wetland, subject to approval from the local authority and from the service providers. The interface between the conduits and the edge of the wetland system must be sealed to prevent flows migrating along the services trench. Detection tape must be placed above the conduits to clearly mark their location.

A 'Dial Before You Dig' search must be completed both during the design process and before the wetland system is constructed to determine the presence of services. If services are present, then they need to be accurately located and the superintendent consulted about appropriate construction procedures.

4.2.5 MAINTENANCE ACCESS

Refer to design drawings for location, width, slope, and surface finish of access tracks. Refer to **Section 3.6** for further information on access tracks.

4.2.5.1 CONCRETE ACCESS TRACKS

All concrete access tracks, including the base of sediment basins, must meet the following requirements:

- Tracks must comply with local authority concrete access requirements.
- Concrete will consist of a mixture of ordinary Portland cement, coarse and fine aggregate, and water.
- Cement must comply with AS 3972.
- Aggregate must comply with AS 2758.
- Concrete must be normal class as defined by AS 1379, Class N25.
- Concrete must be sampled and tested in accordance with the provisions of AS 1012 (Method of Testing Concrete).
- Reinforcement will be deformed bars or welded wire fabric and comply with AS4671 as appropriate.

- Construction joints to be in accordance with the design drawings.

4.2.5.2 GRAVEL ACCESS TRACKS

All gravel access tracks must meet the following requirements.

- Gravel access tracks must be comprised of well-graded crushed or rock-soil aggregate that is free from deleterious materials with no more than two thirds of the percentage, by weight, being able to pass through a 0.425 mm sieve.
- Fill is to be compacted to 98% maximum dry density, using a modified compactive effort (in compliance with AS 1289-5.2.1) or 70% minimum density index (in compliance with AS 1289-1.2.1).
- Where any regular access by heavy vehicles is required, tracks should be comprised of a suitable depth (typically 200 mm) of larger ballast (75 mm diameter).

4.3 Landscape specifications

The following sections describe the main issues that must be considered when preparing for and undertaking landscape works within the wetland.

4.3.1 TOPSOIL

At least 200 mm topsoil must be provided in all areas of the wetland, except for the sediment basin where the topsoil only extends to 500 mm below NWL.

Topsoil must be tested by a National Association of Testing Authorities (NATA)-accredited laboratory and must comply with AS 4419 Soils for landscaping and garden use. The topsoil should be rejected if the proposed topsoil has high salt levels, extremely low levels of carbon (< 5%), or any other extreme characteristic that may restrict plant growth. Note: the AS 4419 requirement for % organic matter content does not apply. Topsoils used in wetlands must have a minimum of 5% organic matter content. The laboratory testing will identify and recommend

any amelioration requirements. The results of the topsoil test must be given to the site superintendent and wetland designer for review before the topsoil is installed.

The topsoil can be sourced from the in-situ topsoils or from soil suppliers. In-situ topsoils can be used for wetland macrophyte zone and batters; however, laboratory soil testing in accordance with AS 4419 is required to ensure the topsoil will support plant growth. If the in-situ topsoil is unsuitable, new topsoil should be purchased from a soil supplier. Purchased soils must still comply with AS 4419.

Weed infested soils should be avoided, particularly soils containing aggressive pasture grasses tolerant of moist conditions. If these weeds are present in the in-situ topsoils, and no other sources of topsoil are available, a minimum of 50 mm should be scraped from the soil surface and discarded.

4.3.2 MULCH

Mulch must be installed in the areas indicated on the design drawings in accordance with the following specifications:

- Obtain mulch from landscape supplier.
- Organic mulch (i.e. sugarcane or tea tree mulch) to be used with less than 5% fines, free of clods of soil, rock, wood slivers and all extraneous material.
- Mulch to be applied after preparation of the planting bed but before planting and other work.
- Mulch to be spread evenly to minimum depth of 75mm. Rake to an even surface finish with the surrounding finished levels and 25 mm below adjacent hard surface finishes of kerbs and pedestrian path.
- Mulch to be kept clear of plant stems by at least 50 mm (to avoid excessive moisture around stems).
- Mulch placed from the normal water level to top of extended detention should be pinned down with an open weave organic mesh or jutemat.

4.3.2.1 PLANT PROCUREMENT

Where possible, plant species of local provenance should be sourced to ensure that they are adapted to the likely growing conditions and to preserve the genetic integrity of local plant populations.

Sufficient time must be allowed to order plants and up to six months lead-time may be required to ensure appropriate species are available. If provenance plant stock is required, up to 18 months may be required to collect seeds and propagate plants.

Wetland plants should be sourced from a nursery with demonstrated experience in growing the species required. The plant stock should be periodically

inspected at the nursery to ensure that suitable plants will be ready when required. Make explicit at the time of ordering or when awarding a plant supply contract that periodic inspections of plants will be required. The following conditions should be checked during the nursery inspection:

- the plants are being grown in clean, weed, and pest-free conditions
- the plants are being grown in the container size specified in the planting plan
- the plants are healthy and well established (i.e. fresh white roots indicate active growth)
- that the plants are being exposed to direct sunlight as a 'hardening off' phase before delivery, i.e. not being taken directly from a shade house to the construction site
- the plants will be at least 300 mm high prior to delivery

Some species are very difficult or slow to propagate. Advice should be sought from a knowledgeable nursery to avoid last minute substitutions due to species unavailability.

Note: Plant species substitutions must be approved by the wetland designer if plant species listed on the planting schedule cannot be procured. This is also applies to changing the number of plants supplied for plant species listed on the planting schedule (i.e. it is not acceptable to increase the number of plants supplied for a particular species to compensate for a lack of plants available for another species unless approved by the wetland designer).

Any changes to the plant species list should be confirmed in writing and changes documented in the planting schedule and planting plan in the landscape drawings.

4.3.2.2 PLANT STOCK

The plant stock delivered to the wetland site must be well developed, sun-hardened, and contain a fully established root ball that does not crumble when removed from its container. The plant stock should be at least 300 mm high to enable plants to cope with inundation.

Immature plants and plants that are too old and pot-bound can be difficult to establish. These plants may remain stunted, be susceptible to herbivory and disease and fail to establish the desired plant cover.

The plant stock must:

- show no sign of pest and disease
- show no signs of nutrient deficiency
- show signs of new growth and general vigour
- be free from weeds
- be clearly labelled

Planting stock should not be accepted if they do not comply with the above conditions. The planting stock must be supplied in the container size specified in the planting schedule. Plants supplied in smaller containers, grown in tubs (need to be bare root divided) or wild harvested or should not be accepted.

The landscape contractor will be responsible for on-site storage prior to planting.

4.3.3 PLANTING PROCEDURE

4.3.3.1 PLANT SET-OUT

The plant set-out is a critical part of the landscape works and must be confirmed with the designer or landscape architect before landscape works commence. It is essential to confirm the placement of the plant species, particularly the plants specified for the macrophyte zone, as these must be planted in the correct location to ensure that the plants are planted at the correct water depth.

The planting zones should be measured from the design drawings and marked with stakes for ease of planting and to reduce the risk of incorrect placement.

Plantings shall be as per the drawings, which indicate the appropriate species for the varying wetland zones. While the macrophytes may look the same, there are considerable differences in each species growth characteristics and tolerance to water depth. For example, macrophyte seedlings planted in an incorrect location (i.e. either too deep or shallow) will struggle to establish and will die over time.

It is important that the macrophytes are planted in groups perpendicular to the flow path through the wetland. The macrophyte planting zones should comprise of mixed species plantings. Contact the site superintendent if the design drawings indicate large areas of single species.

The planting densities should be checked to ensure that there is no excessive clumping of plants. Uneven distribution of planting promotes short circuiting and compromises the wetland treatment performance.

4.3.3.2 PLANTING

The wetland plants are usually planted using hand tools or light machinery such as auger drills. Heavier equipment is not necessary as the topsoil will be uncompacted. Planter holes should be twice the size of the tubestock. The plants should be carefully removed from the tube to ensure their stems do not break from the root ball. Plants should be placed in the topsoil such that all roots are covered by at least 10–20 mm of soil.

4.3.4 PLANT ESTABLISHMENT

4.3.4.1 WATER LEVEL MANAGEMENT

To maximise the chances of successful establishment of the macrophytes, the water level of the wetland system must be controlled during the early stages of vegetation growth.

The wetland should be fully inundated for a period of 1 - 2 weeks prior to planting the macrophyte seedlings. This ensures that the wetland sediments are fully saturated, enabling the sediments to settle and providing ideal conditions for seedling growth.

When first planted, the macrophyte seedlings may be too small to cope with their prescribed water depths. Seedlings intended for inundated sections should ideally have half their stem height above water level during the early stages of establishment, and must not have any less than one third of their stem height above the water level. This may not be possible if planting stock is immature and initially planted at the intended depth (i.e. normal water level). Similarly, if planted too deeply, submerged macrophyte seedlings will not be able to access sufficient light in the open water zones.

The wetland water depth must be controlled in the establishment of the wetland plants. This can be achieved by controlling the outlet valve, removing the outlet control structure (riser pipe or weir), isolating inflows from the sediment basins to the macrophyte zone, and pumping out of the macrophyte zone if required. Refer to the Water by Design Wetlands Construction and Establishment Guidelines for a suggested approach.

Water level adjustments must be confirmed with the Superintendent with input from the wetland designer.

Water level control will need to be staged throughout the planting process to ensure that the plants in deep

marsh zones are not inundated whilst plants higher in shallow marsh zones receive adequate water. The deep marsh zones should have a water depth of approximately 0.15 - 0.2 m for at least the first 6 - 8 weeks, provided that the tubestock planted has a minimum 300mm in height. This will ensure the deep marsh zone is inundated to a shallow depth whilst the sediments in shallow marsh zone remains moist providing suitable conditions for plant establishment.

Vegetation planted in the ephemeral batter and terrestrial zones of the wetland will require ongoing watering.

The design operating water level within the wetland can be established when it is clear that the wetland plants have matured to the point where at least half of the stem is above the NWL.

4.3.4.2 IRRIGATION

Terrestrial and ephemeral batter plants must be regularly irrigated during the establishment phase. The frequency of irrigation will depend on the time of year and weather. The irrigation program outlined below must be followed unless a variation is agreed by the superintendent.

Week 1–6 Five irrigation days per week.
Week 6–10 Three irrigation days per week.
Week 11–15 Two irrigation days per week.

In the absence of rain, it is recommended that each plant receives 2.5–5 L of water per week during the first six weeks (i.e. approximately 40 mm of watering per week during establishment).

After an initial four-month period, irrigation may still be required, particularly during the first winter or dry period. Watering requirements for healthy vegetation can be determined by ongoing inspections.

4.3.4.3 WEED CONTROL

Regular weed control is important to ensure that weeds do not out compete the beneficial wetland plants. Weeds are to be managed through the landscape establishment period through regular inspection (minimum fortnightly inspection) and removal of weeds by hand.

Regular weeding must be undertaken to minimize the establishment of weed cover in the wetland. Regular weed removal ensures the weeds are unable to establish large populations and propagate (i.e. the weeds are removed before they can set seed).

Most weed seeds that enter the wetland will find it difficult to establish due to the permanently wet nature of sediments. Management of native emergent macrophyte species such as *Typha* or *Phragmites* will be required, as these species readily establish in wetlands and are able to out-compete other less vigorous emergent macrophyte species.

Herbicides should not be used to control weeds in the wetland unless specifically authorized by the superintendent. Where a wetland has become weed infested with a declared weed (i.e. floating weed such as *Salvinia*) and herbicides are to be used, the herbicides must be carefully selected and be in accordance with the relevant legislation to avoid potential impact on downstream ecosystems.

Where possible, herbicides should be applied to the weeds via painting rather than spraying. Weed spraying and any use of chemical must be undertaken by staff with relevant training and certification such as a Chemcert certificate.

4.3.5 MEASURES OF SUCCESSFUL PLANT ESTABLISHMENT

The wetland vegetation is considered to be 'established' when the plants have reached reproductive maturity and sufficient vegetation cover has been established across the wetland. The vegetation growth throughout the wetland must be recorded through three-monthly photo logs.

The following conditions should be achieved at the completion of the plant establishment period:

- Plants must be healthy and free from disease.
- Minimum vegetation height is 500 mm (except for submerged plants and groundcovers).
- Emergent macrophytes have reached reproductive maturity (seed heads are present on the majority of plants)
- The macrophyte zone must have at least 80% vegetation cover comprising of emergent macrophytes (calculated at NWL). Submerged vegetation must be present in open water areas.
- The ephemeral batter and terrestrial areas must have at least 90% vegetation cover. Any areas without established vegetation cover must be mulched.



Chapter 5 Worked Example

Photo: Paul Dubowski BMT WBM

5.1 Constructed Wetland Worked Example

As part of a residential development in the greater Brisbane area, stormwater runoff is to be delivered to a constructed wetland for water quality treatment. An illustration of the site and proposed layout of the wetland is shown in **Figure 46**. This worked example describes the design process for each component of the constructed wetland: sediment basin (including the bypass weir), macrophyte zone, macrophyte zone outlet and high flow bypass channel.

CATCHMENT CHARACTERISTICS

The development is a typical detached housing estate (15 lots/ hectare) served by 14 m wide local road reserves. Due to the moderate to steep

gradient through the contributing catchment (10 ha), stormwater runoff is collected and conveyed to the wetland sediment basin via conventional piped drainage with minor storm (2 year ARI) flows discharged to the wetland sediment basin via a 975 mm diameter pipe and major storm (50 year ARI) entering via overland flow.

SITE CHARACTERISTICS

The site has a moderate fall of 2.5 m from south to north and is constrained by roads to the west and north and by steeper grades to the east. Soils through the site have been classified as clay.

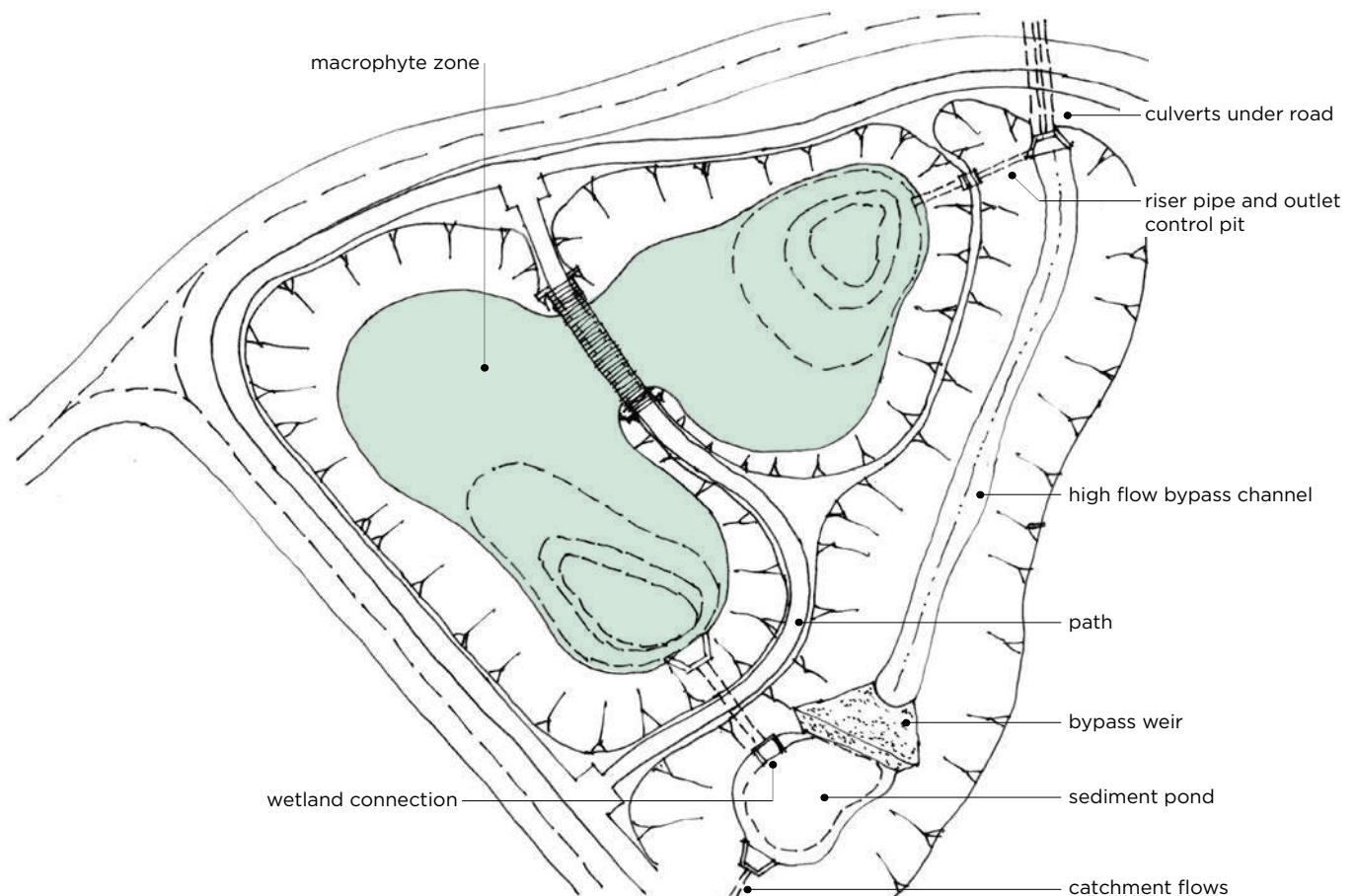

FIGURE 46: Layout of Proposed Wetland System

CONCEPTUAL DESIGN

The conceptual design of the constructed wetland (as shown in **Figure 46**) established the following key design elements to ensure effective operation:

- wetland macrophyte zone extended detention depth of 0.5 m, permanent pool level of 11.5 m AHD and an area of 7000 m²
- sediment basin permanent pool level of 11.7 m AHD, which is 0.2 m above the permanent pool level of the macrophyte zone
- bypass weir ('spillway' outlet) level of 12 m AHD set at the top of extended detention in the wetland macrophyte zone and 0.3 m above the sediment basin permanent pool level
- high flow bypass channel longitudinal grade of 1.5%.

During the conceptual design phase, the configuration described above and shown in **Figure 46** was modelled using MUSIC to ensure the stormwater discharges from the site comply with local authority water quality objectives (WQOs). In this case, delivering the local authority WQOs equates to an 80 % reduction in mean annual TSS load, more than 60 % reduction in mean annual TP load and 45 % reduction in mean annual TN load. To achieve these objectives, the wetland concept required a macrophyte zone area of 7000 m², extended detention depth of 0.5 m and detention time of 72 hours.

5.1.1 STEP 1: VERIFY SIZE FOR TREATMENT

The key functional elements of the constructed wetland developed as part of the conceptual design (i.e. area, extended detention depth) were not adjusted as part of the detailed design.

5.1.2 STEP 2: DETERMINE DESIGN FLOWS

The site has a contributing catchment of 10 ha which is drained via conventional pipe drainage. Both the minor storm (2 year ARI) and the major storm (50 year ARI) flows enter the sediment basin of the wetland. Therefore, the 50 year ARI peak flow sets the 'above design flow'. The 'design operation flow', which is required to size the sediment basin and the sediment basin connection to the macrophyte zone, is the 1 year ARI peak flow.

Design flows are established using the Rational Method using QUDM (DEWS, 2013) and local government guidelines. The time of concentration (t_c) was calculated using the procedures outlined in Section 4.6 of QUDM and found to be 10 minutes. The coefficient of runoff was taken from local government guidelines as follows:

$$C_{10} = 0.8 \text{ (from local government guidelines)}$$

	C RUNOFF		
ARI	1	10	50
QUDM Factor	0.8	1	1.15
C_{ARI}	0.64	0.8	0.92

$$\text{Catchment area, } A = 10 \text{ ha}$$

$$\text{Rainfall Intensities, } t_c = 10 \text{ mins}$$

$$I_1 = 90 \text{ mm/hr}$$

$$I_{50} = 227 \text{ mm/hr}$$

$$\text{Rational Method } Q = CIA/360$$

$$\text{'Design operation flow' (1-year ARI)} = 1.60 \text{ m}^3/\text{s}$$

$$\text{'Above design flow' (50-year ARI)} = 5.80 \text{ m}^3/\text{s}$$

5.1.3 STEP 3: DESIGN SEDIMENT BASIN

The design of the sediment basin is undertaken in accordance with the design procedures outlined in Chapter 3 with a summary of the key sediment basin elements provided below.

5.1.3.1 SEDIMENT BASIN (SEDIMENTATION BASIN) SIZE

Confirmation of the sedimentation basin area is provided by using **Equation 1**:

$$R = 1 - \left[1 + \frac{1}{n} \cdot \frac{V_s}{Q/A} \cdot \frac{(d_e + d_p)}{(d_e + d^*)} \right]^{-n}$$

Based on the description of the sedimentation basin and wetland provided in **Section 3.4.2**, the following applies:

- $d_p = 2.0$ m
- $d^* = 1.0$ m
- $d_e = 0.3$ m
- $V_s = 0.011$ m/s for 125 μm particles
- $R = 0.9$ (90% removal target)
- $Q =$ design operation flow rate (1 year ARI) = 1.25 m³/s

A sedimentation basin area of 360 m² is required to capture 90% of the 125 μm particles for flows up to the 'design operation flow' (1 year ARI = 1.6 m³/s).

An aspect ratio of 1 (W) to 4 (L) is adopted based on the available space (**Figure 4-14**). Using **Figure 4-4** (configuration I), the hydraulic efficiency (λ) is estimated to be approximately 0.4. This value is less than desirable; however, site constraints prevent any other configuration. The turbulence factor (n) is computed from **Equation 2** to be 1.67. Thus:

$$\lambda = 0.4$$

$$n = 1.67$$

Inserting the above parameters into **Equation 1**, the required sedimentation basin area to achieve a target sediment (125 μm) capture efficiency of 90 % is 319m². With a W to L ratio of 1:4, the notional dimensions of the basin are approximately 8.9 m x 35.8 m.

A further consideration in the design of the sediment basin is the provision of adequate storage for settled sediment to prevent the need for frequent desilting. A desirable frequency of basin desilting is once every five years. To ensure this storage zone is appropriate the following must be met:

Sedimentation Basin Storage Volume (V_s) > Volume of accumulated sediment over 5 years ($V_{s:5\text{yr}}$)

The sedimentation basin storage volume (V_s) is defined as the storage available in the bottom half of the sediment basin permanent pool. Considering the internal batters of the sediment basin will be 2:1 (H:V) below the permanent water level the area of the basin at 1 m depth is 153 m² and at 2 m depth 17 m². Therefore, the sedimentation basin storage volume V_s is 85 m³.

The volume of accumulate sediments over 5 years ($V_{s:5\text{yr}}$) is established using **Equation 3** (using a sediment discharge rate of 0.6 m³/Ha/yr):

$$V_{s:5\text{yr}} = A_c R L_o F_c = 10 \times 0.9 \times 0.6 \times 5 = 27 \text{ m}^3$$

Therefore, $V_s > V_{s:5\text{yr}}$, hence OK.

5.1.3.2 SEDIMENT BASIN CONNECTION TO MACROPHYTE ZONE

The configuration of the hydraulic structure connecting the sediment basin to the macrophyte zone consists of an overflow pit (in the sediment basin) and a connection pipe with the capacity to convey the 'design operation flow' (1-year ARI = 1.60 m³/s). As defined by the conceptual design the follow design elements apply:

- Sediment basin permanent pool level (overflow pit crest level) = 11.7 m AHD which is 0.2 m above the permanent pool level of the macrophyte zone
- Bypass weir ('spillway' outlet) crest level = 12 m AHD which is the top of extended detention for the wetland and 0.3 m above the sediment basin permanent pool level.

It is common practice to allow for 0.3 m of freeboard above the afflux level when setting the top of embankment elevation.

OVERFLOW PIT

According to **Section 3-43**, two possible flow conditions need to be checked: weir flow conditions (with extended detention of 0.3 m) and orifice flow conditions.

WEIR FLOW CONDITIONS

From **Equation 4**, the required perimeter of the outlet pit to pass 1.6 m³/s with an afflux of 0.3 m can be calculated assuming 50% blockage:

$$P = \frac{Q_{des}}{B \cdot C_w \cdot h^{3/2}}$$

$$P = \frac{1.6}{0.5 \cdot 1.66 \cdot 0.3^{3/2}} = 11.7m$$

ORIFICE FLOW CONDITIONS

From **Equation 5**, the required area of the outlet pit can be calculated as follows:

$$A_o = \frac{Q_{des}}{B \cdot C_d \cdot \sqrt{2 \cdot g \cdot h}}$$

$$A_o = \frac{1.6}{0.5 \cdot 0.6 \cdot \sqrt{2 \cdot g \cdot (0.3)}} = 2.2 m^2$$

In this case the weir flow condition is limiting. Considering the overflow pit is to convey the 'design operation flow' (1 year ARI) or slightly greater, a 2000 x 4000 mm pit size is adopted providing a perimeter of 12 m which is greater than the 11.7 m calculated using the weir flow equation above. The top of the pit is to be fitted with a letter box grate. This will ensure large debris does not enter the 'control' structure while avoiding the likely of blockage of the grate by smaller debris.

CONNECTION PIPE(S)

As the connection pipe (i.e. between the sediment basin and the macrophyte zone) is to be submerged, the size can be determined by firstly estimating the required velocity in the connection pipe using the following:

$$h = \frac{2 \cdot V^2}{2 \cdot g}$$

Where **h** = maximum available head level driving flow through the pipe (defined as the bypass weir spillway outlet crest level minus the normal water level in the macrophyte zone = 0.5 m)

V = pipe velocity (m/s)

g = 9.79 m/s²

Note: the coefficient of 2 in the equation is a conservative estimate of the sum of entry and exit loss coefficients ($K_{in} + K_{out}$).

Hence, **V** = (9.79 x 0.5)^{0.5} = 2.21 m/s

The area of pipe required to convey the 1 year ARI is then calculated using the continuity equation by dividing the 1 year ARI flow ($Q_2 = 1.60$ m³/s) by the velocity:

$$A_{pipe} = \frac{Q}{V} = \frac{1.60}{2.21} = 0.724 m^2$$

This area is equivalent to two (2) 675 mm reinforced concrete pipes (RCPs). The obvert of the pipes is to be set below the permanent water level in the wetland macrophyte zone (11.5 m AHD) meaning the invert is at 10.80 m AHD.

5.1.3.3 HIGH FLOW BYPASS WEIR

All flows in excess of the 'design operation flow' and up to the 'above design flow' are to bypass the wetland macrophyte zone. This is facilitated by a high flow bypass weir ('spillway' outlet) designed to convey the 'above design flow' (50 year ARI) with the weir crest level 0.3 m above the permanent pool of the sediment basin.

Assuming a maximum afflux of 0.3 m, the weir length is calculated using the weir flow equation (**Equation 4**):

$$L = \frac{Q_{des}}{C_w \cdot H^{3/2}}$$

$$L = \frac{5.8}{1.66 \cdot 0.3^{3/2}} = 21.3 \text{ m (adopt 22m)}$$

To ensure no flows breach the embankment separating the sediment basin and the macrophyte zone the embankment crest level is to be set at 12.6 m AHD (i.e. 0.3 m freeboard on top of the maximum afflux level over the high flow bypass weir).

Sediment basin Area	= 360 m ² set at 11.7 m AHD
Overflow pit	= 2000 x 4000 mm with letter box grate set at 11.7 m AHD
Pipe connection (to wetland)	= 2 x 675 mm RCPs at 10.80 m AHD
High flow bypass weir	= 22 m length set at 12.0 m AHD

5.1.4 STEP 4: DESIGNING THE MACROPHYTE ZONE

5.1.4.1 LENGTH TO WIDTH RATIO AND HYDRAULIC EFFICIENCY

A macrophyte zone area of 7000 m² was established as part of the conceptual design and verified as part of Step 1. The layout of the wetland as presented in Figure 46 represents a length (L) to width (W) ratio of 6 to 1. This aspect ratio represents a shape configuration in between Case G and Case I in Figure 17 (but closer to Case G). Thus, the expected hydraulic efficiency (λ) is 0.6-0.7.

Aspect Ratio	= 6(L) to 1(W)
Hydraulic Efficiency	~ 0.6-0.7

5.1.4.2 DESIGNING THE MACROPHYTE ZONE BATHYMETRY

Being a typical residential catchment, the wetland macrophyte zone has been configured to target sediment and nutrient capture. Therefore, the macrophyte zone of the wetland is divided into two marsh zones and an open water zone as depicted in **Figure 47** and described below:

- The bathymetry across the two marsh zones is to vary gradually over the length of the macrophyte zone, ranging from NWL to 0.4 m below the permanent pool level (see **Figure 47** and **Table 16**). The shallow marsh zone is to be located adjacent to the pathway and bridge crossing mid way along the wetland.
- The depth of the open water zone in the vicinity of the outlet structure is to be 1.5 m below the permanent pool level.
- The marsh zones are arranged in bands of equal depth running across the flow path to optimise hydraulic efficiency and reduce the risk of short-circuiting.

TABLE 16 INDICATIVE BREAK OF MARSH ZONES

ZONE	DEPTH RANGE (M)	PROPORTION OF MACROPHYTE ZONE SURFACE AREA (M)
Open Water (Pool)	>0.7 below permanent pool	10%
Submerged Marsh	0.4 – 0.7 below permanent pool	10%
Deep Marsh	0.2 – 0.4 below permanent pool	40%
Shallow Marsh	0.0 – 0.2 below permanent pool	40%



FIGURE 47: LAYOUT OF MARSH ZONES

5.1.4.3 MACROPHYTE ZONE EDGE DESIGN FOR SAFETY

The batter slopes on approaches and immediately under the permanent water level have to be configured with consideration of public safety:

- Generally, batter slopes of 1(V):8(H) from the top of the extended detention depth to 0.35 m beneath the water line has been adopted.
- The general grade through the wetland below the waterline is 1(V):8(H) or flatter.
- The batters directly adjacent and within the open water zones of the macrophyte are limited to 1(V):8(H).

Reference is made to the construction drawings in **Section 6.7.12** for typical long and cross sections of the macrophyte zone.

5.1.5 STEP 5: DESIGN THE MACROPHYTE ZONE OUTLET

5.1.5.1 RISER OUTLET – SIZE AND LOCATION OF ORIFICES

The riser outlet is designed to provide a uniform notional detention time in the macrophyte zone for the full range of possible extended detention depths. The target maximum discharge from the riser is computed as the ratio of the volume of the extended detention to the notional detention time as follows (**Equation 9**)

$$Q_{\text{max riser}} = \frac{\text{extended detention storage volume (m}^3\text{)}}{\text{notional detention time (s)}}$$

Extended detention storage = 7000 m² x 0.5 m
extended detention
= 3500 m³

Notional detention time = 72 hrs x 3600 s/hr

Therefore, Q_{max} = 3500/(72 x 3600)
= 0.0135 m³/s = 13.5 L/s

The placement of orifices along the riser and determining their appropriate diameters involves iterative calculation using the orifice equation (**Equation 5**) over discrete depths along the length of the riser. **Equation 5** is given as:

$$A_o = \frac{Q}{C_d \sqrt{2 \cdot g \cdot h}}$$

Where C_d = Orifice Discharge Coefficient (0.6)

h = Depth of water above the centroid of the orifice (m)

A_o = Orifice area (m²)

Q = required flow rate to drain the volume of the permanent pool in 12 hours

The size of each orifice is sized to achieve the notional detention time (48 hrs) over the full range of extended detention depths. This was performed in a spreadsheet application and the resulting riser configuration can be described as follows:

- Orifices are located at 0.125 m intervals along the length of riser at 0 m, 0.125 m, 0.250 m and 0.375 m above the permanent pool level (11.5 m AHD).
- Three orifice diameters of 30 mm, 35 mm and 40 mm were selected and the numbers required at each level are summarised in **Table 17** and **Figure 48** below.

TABLE 17 ITERATIVE SPREADSHEET CALCULATIONS FOR STAGE-DISCHARGE RELATIONSHIP

Orifice Positions (m above 11.5m AHD)		0	0.125	0.25	0.0375		
Orifice Diameter (mm)		40	35	30	30		
Number of orifices		4	4	2	2		
EXTENDED DET. DEPTH (M ABOVE 11.5M AHD)	EXTENDED DET. VOLUME (M3)	FLOW AT GIVEN EXT. DET. DEPTHS (L/S)				TOTAL FLOW (L/S)	NOT. DETENTION TIME (HRS)
0	0	0.00				0.00	
0.125	875	4.72	0			4.72	51.51
0.25	1750	6.67	3.61	0		10.29	47.26
0.375	2625	8.17	5.11	1.33	0	14.61	49.92
0.5	3500	9.44	6.26	1.88	1.33	18.90	51.45

The stage-discharge relationship of the riser is plotted in the chart below (Figure 48) and shows that the riser maintains a linear stage discharge relationship.

At the top of extended detention the high flow bypass is activated; therefore, the riser pipe has no role in managing of flows greater than the Q_{max} (18.9 L/s) of riser pipe. An upstand riser pipe diameter of 225 mm is selected.

As the wetland is relatively small and the required orifices are small, it is necessary to include measures to prevent blocking of the orifices. The riser is to be installed within an outlet pit, as per Figure 48, with a pipe connection to the permanent pool of the macrophyte zone. The connection is via a 225 mm diameter pipe. The pit is accessed via the locked screen on top of the pit.

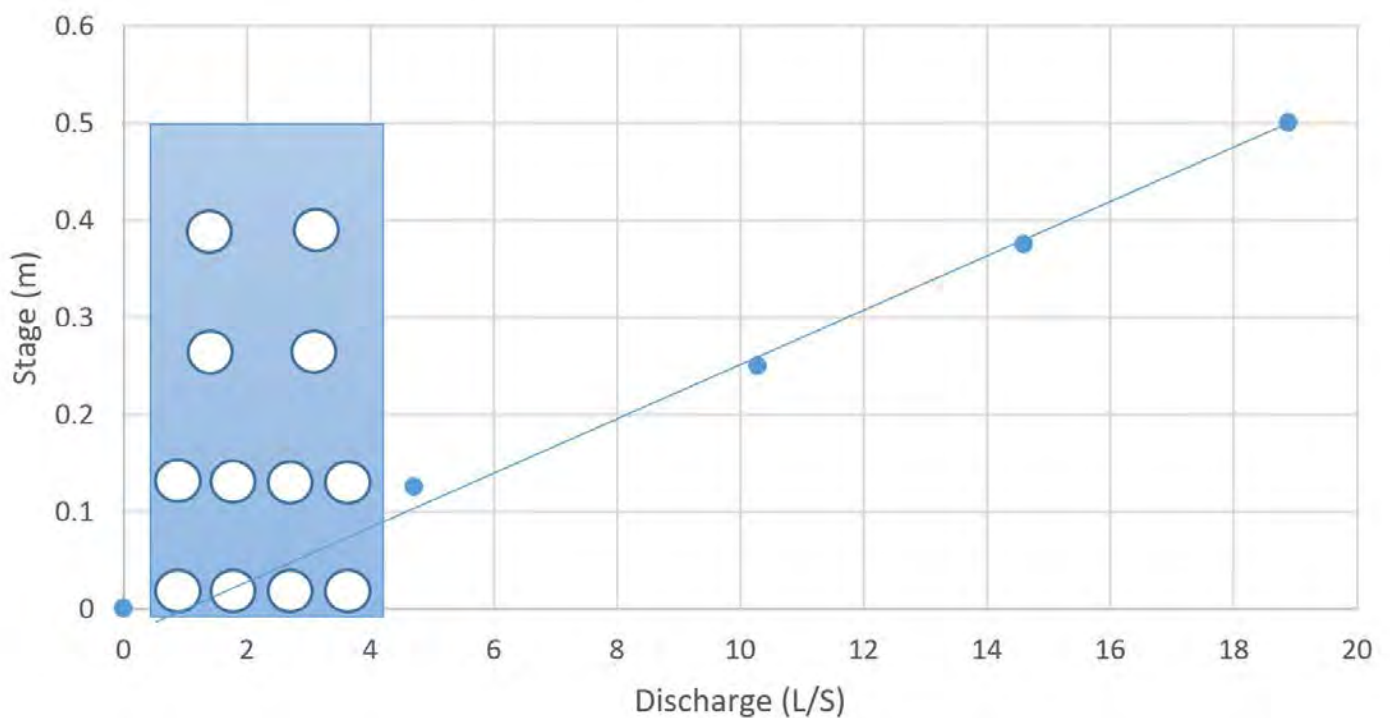

FIGURE 48 Riser Pipe Configuration Showing Discharge Stage Relationship

5.1.5.2 MAINTENANCE DRAINS

To allow access for maintenance, the wetland is to be drained via a maintenance drain (i.e. pipe) that connects the low points in the macrophyte bathymetry. The drain must be sized to draw down the permanent pool of the macrophyte zone in 12 hours with allowance for manual operation (i.e. inclusion of valve).

The mean flow rate to draw down the macrophyte zone over a notional 12 hour period is as follows:

Permanent Pool Volume ~ 1750 m³ (assuming approximate 0.25 m nominal depth)

$$Q = 1750 / (12 \times 3.6) = 40.5 \text{ L/s}$$

The size of the of maintenance drain can be established using the Manning's equation assuming the drain/ pipe is flowing full and at 0.5 % grade:

$$Q = \frac{A \cdot R^{2/3} \cdot S^{1/2}}{n}$$

- Where **A** = cross sectional area of drain (m²)
R = hydraulic radius (m) (pipe area/ wetted perimeter)
S = 0.5% (0.005m/m)
n = 0.012

Giving pipe diameter of 240 mm – adopt 225 mm diameter pipe meaning a notional draining time of 14 hrs.

LEVEL	ORIFICES	ORIFICE DIAMETER
11.5 m AHD	4	40 mm
11.625 m AHD	4	35 mm
11.75 m AHD	2	30 mm
11.875 m AHD	2	30 mm

- Maintenance drain = 225 mm diameter pipe at 0.5 % grade
 Maintenance control = 150 mm diameter valve
 Discharge pipe = 225 mm diameter at 0.5 % grade

The size of the valve can be established using the orifice equation, assuming the orifice operates under inlet control (**Equation 5**):

$$A_o = \frac{Q}{C_d \sqrt{2 \cdot g \cdot h}}$$

- Where **Q** = 40.5 L/s (0.0405 m³/s)
C_d = 0.6
h = 0.33 m (one third of permanent pool depth)
 So **A_o** = 0.0104 m² corresponding to an orifice diameter of 115 mm – adopt 150mm

5.1.5.3 DISCHARGE PIPE

The discharge pipe of the wetland conveys the outflow of the macrophyte zone to the receiving waters (or existing drainage infrastructure). Under normal operating conditions, this pipe will need to have sufficient capacity to convey the larger of the discharges from the riser (18.9 L/s) or the maintenance drain (30.5 L/s). Considering the maintenance drain flow is the larger of the two flows the discharge pipe size is set to the size of the maintenance drain (225 mm pipe at 0.5% as calculated above).

Riser outlet = 225 mm diameter pipe with following orifice detail:

5.1.6 STEP 6: DESIGN HIGH FLOW BYPASS CHANNEL

The bypass channel accepts 'above design flow' (50 year ARI = 5.80 m³/s) from the sediment basin (via the bypass weir) and conveys this flow around the macrophyte zone of the wetland. The configuration of the bypass channel can be designed using Manning's Equation:

$$Q = \frac{A \cdot R^{2/3} \cdot S^{1/2}}{n}$$

Where **Q** = 'above design flow' (50-year ARI = 5.80 m³/s)
A = cross section area (m²)
R = hydraulic radius (m)
S = channel slope (1.5%)
n = Manning's roughness factor

A turf finish is to be adopted for the bypass channel and a Manning's **n** of 0.03 is considered appropriate for flow depths more than double the height of the grass.

Assuming there is a 0.3 m drop from the bypass weir crest to the upstream invert of the bypass channel and 5(H):1(V) batters, the base width of the bypass channel can be established by setting the maximum flow depth in the bypass channel at 0.3 m. This ensures flow in the channel does not backwater (i.e. submerge) the bypass weir.

For base width = 16 m, **Q** = 5.9 m³/s > 'Above Design flow' (5.8m³/s)

High flow bypass channel – Base width of 16 m, batters of 5(H):1(V) and longitudinal slope of 1.5%.

5.1.7 STEP 7: VERIFICATION CHECKS

5.1.7.1 MACROPHYTE ZONE RESUSPENSION PROTECTION

A velocity check is to be conducted for when the wetland is at the top of the extended detention level and the riser is operating at design capacity. This check is to ensure velocities through the macrophyte zone (**V**_{macrophyte zone}) are less than 0.1 m/s to avoid potential scour of biofilms from the wetland plants (macrophytes) and resuspension of the sediments):

$$\frac{Q_{\max \text{ riser}}}{A_{\text{section}}} < 0.1 \text{ m/s}$$

Where **Q**_{max riser} = target maximum discharge (defined in **Equation 7**) (m³/s)

A_{section} = wetland cross sectional area at narrowest point*, measured from top of extended detention (m²)

* *minimum wetland cross section is used when undertaking this velocity check*

Wetland width (W) = 34 m
 (based on the 6 (L) : 1 (W) length to width ratio)

Minimum depth at top of extended detention depth is within the marsh = 0.6 m depth

Giving **A**_{section} = 34 m x 0.6m = 20.4 m²
Q_{max riser} = 18.9 L/s (0.0189 m³/s)

Therefore,
V_{macrophyte zone} = 0.0189/0.6/34 = 0.0009 m/s < 0.1 m/s (OK)

5.1.7.2 CONFIRM TREATMENT PERFORMANCE

The key functional elements of the constructed wetland developed as part of the conceptual design (i.e. area, extended detention depth) were not adjusted as part of the detailed design. Therefore, the performance check undertaken in Step 1 still applies.

5.1.8 STEP 8: VEGETATION SPECIFICATION

The vegetation specification and recommended planting density for the macrophyte zone have been adapted from Section **Table 12** and **Table 13** and are summarised in **Table 18** below.

The reader is referred to **Section 3.8** for further discussion and guidance on vegetation establishment and maintenance.

TABLE 18 WORKED EXAMPLE VEGETATION LIST

ZONE	PLANT SPECIES	PLANTING DENSITY (PLANTS/M2)
Littoral zone	Carex appressa	8
	Isolepis nodosa	8
Shallow Marsh	Eleocharis equisetina	10
	Juncus usitatus	10
Deep Marsh	Baumea articulata	4
	Schoenoplectus validus	4

5.1.9 DESIGN CALCULATION SUMMARY

The sheet below shows the results of the design calculations.

CONSTRUCTED WETLANDS DESIGN CALCULATION SUMMARY				
CALCULATION TASK		CALCULATION SUMMARY		
		OUTCOME		CHECK
CATCHMENT CHARACTERISTICS				
	Catchment area	10	ha	
	Catchment land use (i.e residential, commercial etc.)	Residential		✓
	Storm event entering sediment basin (minor or major)	50yr ARI		✓
	Conceptual Design			
	Macrophyte zone area	7000	m ²	✓
	Permanent pool level of macrophyte zone	11.5	m AHD	✓
	Extended detention depth (0.25-0.5m)	0.5	m	✓
	Notional detention time	48	hrs	✓
1 CONFIRM TREATMENT PERFORMANCE OF CONCEPT DESIGN				
	Total suspended solids (Figure 6-2)	81	% removal	✓
	Total phosphorus (Figure 6-3)	67	% removal	✓
	Total nitrogen (Figure 6-4)	45	% removal	✓
	Macrophyte Area	7000	m ²	✓
2 DETERMINE DESIGN FLOWS				
	'Design operation flow' (1 year ARI)	1	year ARI	✓
	'Above design flow' (either 2, 10, 50 or 100 year ARI)	50	year ARI	✓
	Time of concentration			
	(Refer to relevant local government guidelines and QUDM)	10	minutes	✓
	Identify rainfall intensities			
	'Design operation flow' - 11 year ARI	90	mm/hr	✓
	'Above design flow' - 12 year ARI or 110 or 1100 year ARI	227	mm/hr	✓
	Peak design flows			
	'Design operation flow' - 1 year ARI	1.6	m ³ /s	✓
	'Above design flow' - 2, 10 or 100 year ARI	5.8	m ³ /s	✓
3 DESIGN SEDIMENT BASIN				
	Refer to sedimentation basin (Chapter 4) for detailed check sheet			
	Is a GPT required?			
	Suitable GPT selected and maintenance considered?	No		✓
	Sediment basin size			
	Target Sediment Size for Sediment basin	125	µm	✓
	Capture efficiency	90	%	✓
	Sediment basin area (Figure 4.2 in Chapter 4)	360	m ²	✓
	V _s > V _{s:5yr}	Yes		✓

CONSTRUCTED WETLANDS DESIGN CALCULATION SUMMARY

CALCULATION TASK		CALCULATION SUMMARY		
		OUTCOME		CHECK
SEDIMENT BASIN CONNECTION TO MACROPHYTE ZONE				
	Overflow pit crest level	11.7	m AHD	✓
	Overflow pit dimension	4000 x 2000	L x W	✓
	Provision of debris trap	Yes		✓
	Connection pipe dimension	2 x 675	mm diam	✓
	Connection pipe invert level	10.8	m AHD	
HIGH FLOW BY-PASS WEIR				
	Weir Length	22	m	✓
	High flow by-pass weir crest level (top of extended detention)	12.0	m AHD	✓
4 DESIGNING THE MACROPHYTE ZONE				
	Area of Macrophyte Zone	7000	m ²	✓
	Aspect Ratio	6:1	L:W	✓
	Hydraulic Efficiency	0.6-0.7		✓
5 DESIGN MACROPHYTE ZONE OUTLET				
	Design macrophyte zone outlet			
	Riser outlet			
	Target maximum discharge (Q _{max})	18.9	m ³ /s	✓
	Uniform Detention Time Relationship for Riser	Yes		✓
	Maintenance Drain			
	Maintenance drainage rate (drain over 12hrs)	40.5	m ³ /s	✓
	Diameter of maintenance drain pipe	225	mm	✓
	Diameter of maintenance drain valve	150	mm	✓
	Discharge Pipe			
	Diameter of discharge pipe	225	mm	✓
6 DESIGN HIGH FLOW BY-PASS 'CHANNEL'				
	Design high flow by-pass 'channel'			
	Longitudinal slope	1.5	%	✓
	Base width	16	m	✓
	Batter slopes	5:1	H:V	✓
7 VERIFICATION CHECKS				
	Macrophyte zone re-suspension protection			✓
	Confirm treatment performance			✓

5.2 REFERENCES

- Australian Standards, AS1012 – Methods of testing concrete
- Australian Standards, AS2758 – Aggregates and rock for engineering purposes
- Australian Standards (1998), AS 1289.1.2.1 – Methods of testing soils for engineering purposes - Sampling and preparation of soils - Disturbed samples - Standard method
- Australian Standards (2003), AS 1289.5.2.1 – Methods of testing soils for engineering purposes - Soil compaction and density tests - Determination of the dry density/ moisture content relation of a soil using modified compactive effort
- Australian Standards (2003), AS 4419 – Soils for landscaping and garden use
- Australian Standards (2007), AS 1379 – Specification and supply of concrete
- Australian Standards (2010), AS 3972 – General purpose and blended cements
- BCC 2001, Sediment Basin Design, Construction and Maintenance: Guidelines, BCC, Brisbane
- Department of Energy and Water Supply (2013) Queensland Urban Drainage Manual, State of Queensland, Brisbane
- Engineers Australia 2006, Australian Runoff Quality, Engineers Australia, ACT, <http://www.arq.org.au/>
- Fair, G.M., and Geyer, J.C. 1954. Water supply and waste-water disposal. John Wiley & Sons, Inc., New York.
- Lake Macquarie City Council (2009) Batter Slope Treatment and Fencing Guidelines for Constructed Wetlands and Flood storages
- Leinster, S 2006, Delivering the Final Product – Establishing Water Sensitive Urban Design Systems, 7th International Conference on Urban Drainage Modelling and 4th International Conference on Water Sensitive Urban Design Book of Proceedings, Volume 2, A Deletic and T Fletcher (eds), Melbourne.
- Melbourne Water, Constructed wetlands design manual
- Persson J, Some NLG and Wong THF 1999, 'Hydraulic efficiency and constructed wetland and ponds', Water Science and Technology, vol. 40 no. 3, pp. 291–289
- Water by Design. Concept Design Guidelines for Water Sensitive Urban Design, South East Queensland Healthy Waterways Partnership, Brisbane
- Water by Design. Construction and Establishment Guidelines: Swales, Bioretention Systems and Wetlands, South East Queensland Healthy Waterways Partnership, Brisbane
- Water by Design. Deemed to Comply Solutions – Stormwater Quality Management, South East Queensland Healthy Waterways Partnership, Brisbane
- Water by Design. Maintaining Vegetation Stormwater Assets, Healthy Waterways Ltd, Brisbane
- Water by Design. MUSIC Modeling Guidelines, South East Queensland Healthy Waterways Partnership, Brisbane
- Water by Design. Transferring Ownership of Vegetated Stormwater Assets, Healthy Waterways Ltd, Brisbane
- Water by Design. Water Sensitive Urban Design Technical Design Guidelines for South East Queensland, South East Queensland Healthy Waterways Partnership, Brisbane
- Work Health and Safety Act 2011 (QLD)



Healthy
land & water
Solutions Protecting Your World

waterbydesign

a Healthy Land and Water initiative

Healthy Land and Water
Level 19, 160 Ann St, Brisbane QLD 4000
PO Box 13204, George St, Brisbane QLD 4003
Ph: (07) 3177 9100
Fax: (07) 3177 9190
Email: info@hlw.org.au
www.hlw.org.au
© Healthy Land and Water 2017-004